

PHILIPS

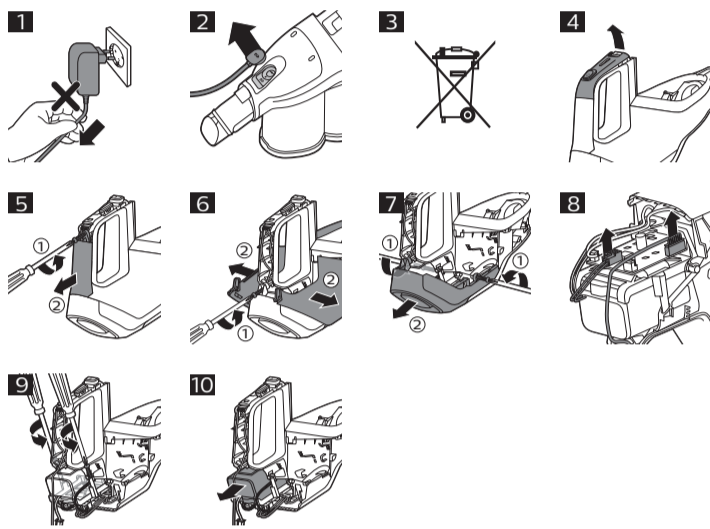

© 2021 Philips Domestic Appliances Holding B.V.
All rights reserved
保留所有权利
3000.062.6136.1 (07/2021)
> 75% 循环再造纸
保留备用

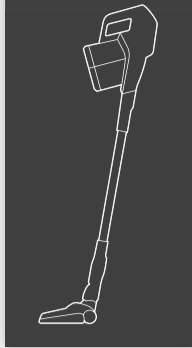

>75 % recycled paper
>75 % papier recyclé

English

Congratulations on your purchase and welcome to Philips! To fully benefit from the support that Philips offers, register your product at www.philips.com/MyVacuumCleaner.

Important safety information

Read this important information carefully before you use the appliance and its accessories and save it for future reference. The accessories supplied may vary for different products.

Danger

- Never vacuum up water or any other liquid. Never vacuum up flammable substances and do not vacuum up ashes until they are cold.
- Never immerse the appliance or the adapter in water or any other liquid, nor rinse it under the tap.

Warning

- Check if the voltage indicated on the adapter corresponds to the local mains voltage before you connect the appliance.
- Always check the appliance before you use it. Do not use the appliance or the adapter if it is damaged. Always replace a damaged part with one of the original type.
- The adapter contains a transformer. Do not cut off the adapter to replace it with another plug, as this causes a hazardous situation.
- This appliance can be used by children aged from 8 years and above and persons with reduced physical, sensory or mental capabilities or lack of experience and knowledge if they have been given supervision or instruction concerning use of the appliance in a safe way and understand the hazards involved. Children shall not play with the appliance. Cleaning and user maintenance shall not be made by children without supervision.
- Always keep the magnetic charging disc away from very small children.
- The plug must be removed from the socket-outlet before cleaning or maintaining the appliance.
- Unplug the adapter if you are not going to use the appliance for some time.
- When storing the appliance for more than a month (without usage or charging), make sure that the battery is charged to at least 50%. Storing the appliance with an empty battery may lead to irreversible damage to the battery.
- Also make sure that the adapter is unplugged when the appliance is stored.
- Do not let the motorized brush move over the mains cords of other appliances or other cables as this may cause a hazard.
- Keep loose clothing, hair and body parts away from the motorized brushes.
- Do not cover or block the ventilation openings when the appliance is operating.
- This vacuum cleaner is designed for household use only. Do not use this vacuum cleaner to vacuum up building waste, cement dust, ashes, fine sand, lime and similar substances. Never use the vacuum cleaner without any of the filters. This damage the motor and shorten the life of the vacuum cleaner. Always clean all parts of the vacuum cleaner as shown in the user manual. Do not clean any parts with water and/or cleaning agents if this is not specifically shown in the user manual.
- Only charge the appliance with the adapter supplied. Only use 25V adapter ZD12D250050EU or 29V adapter ZD12D290050EU. The corresponding adapter number can be found on the adapter.
- Charge, use and store the product at a temperature between 5 °C and 40 °C.
- Do not open, modify, pierce, damage or dismantle the product or battery to prevent batteries from heating up or releasing toxic or hazardous substances. Do not short-circuit, overcharge or reverse charge batteries.
- Keep product and batteries away from fire and do not expose them to direct sunlight or high temperatures.
- If the product becomes abnormally hot or smelly, changes color or if charging takes longer than usual, stop using and charging the product and contact Philips.
- Do not place products and their batteries in microwave ovens or on induction cookers.
- If batteries are damaged or leaking, avoid contact with the skin or eyes. If this occurs, immediately rinse well with water and seek medical care.
- This product contains a rechargeable battery. The battery may only be replaced by a qualified service engineer.
- Take the appliance to an authorized Philips service center when you can no longer recharge it or when it runs out of power quickly.
- To prevent damage, do not use the appliance if the filter is not present in the dust container.

Caution

- During charging, the adapter becomes warm to the touch. This is normal.
- Do not plug in, unplug or operate the appliance with wet hands.
- Do not remove the adapter from the wall socket by pulling at the cord (Fig. 1). When you do not use the charging by plugging, always unplug the appliance by first detaching the magnetic charging disc from the underside of the appliance (Fig. 2).
- Always switch off the appliance after use and before you charge it.
- Never block the exhaust air openings during vacuuming.

- Do not clean the dust container and the dust container lid in the dishwasher. They are not dishwasher-proof.
- Make sure to wash the filter at least once every two weeks by hand only, to ensure best performance. Squeeze until the water is clean. Let the filter dry for 24 hours before reuse.
- Do not clean the filter with scouring pads or abrasive cleaning agents.
- Always use the vacuum cleaner with the filter assembled.
- If you clean the filter with water, make sure that it is completely dry before you put it back into the dust container. Do not dry the filter in direct sunlight, on the radiator or in the tumble dryer.
- Replace the filter if it can no longer be cleaned properly or if it is damaged (see 'Ordering accessories').
- Make sure that the appliance is installed with the charging station attached to the wall according to the instructions in the user manual.
- Be careful when you drill holes in the wall to attach the charging station, to avoid the risk of electric shock.

Electromagnetic fields (EMF)

This Philips appliance complies with all applicable standards and regulations regarding exposure to electromagnetic fields.

Ordering accessories

To buy accessories or spare parts, visit www.philips.com/parts-and-accessories or go to your Philips dealer. You can also contact the Philips Consumer Care Center in your country (see the international warranty leaflet for contact details).

Warranty and support

If you need information or support, please visit www.philips.com/support or read the international warranty leaflet.

Recycling

- This symbol means that electrical products and batteries shall not be disposed of with normal household waste (Fig. 3).
- Follow your country's rules for the separate collection of electrical products and batteries.

Removal of built-in rechargeable battery

The built-in rechargeable battery must only be removed by a qualified professional when the appliance is discarded. Before removing the battery, make sure that the appliance is disconnected from the wall socket and that the battery is completely empty.

Take any necessary safety precautions when you handle tools to open the appliance and when you dispose of the rechargeable battery.

When you handle batteries, make sure that your hands, the product and the batteries are dry.

To avoid accidental short-circuiting of batteries after removal, do not let battery terminals come into contact with metal objects (e.g. coins, hairpins, rings). Do not wrap batteries in aluminum foil. Tape battery terminals or put batteries in a plastic bag before you discard them.

- 1 Disconnect the appliance from the wall socket and let it run until the motor stops.
- 2 Remove the dust container from the appliance.
- 3 Pull the display cover from the top of the handgrip (Fig. 4).
- 4 Undo the screw of the handle cover and pull the handle cover off the appliance (Fig. 5).
- 5 Undo the bottom cover screw (1) and then remove the side panels. (Fig. 6)
- 6 Remove the bottom cover screws on the left and right side (1). Then remove the bottom cover (2) (Fig. 7).
- 7 Disconnect the battery connector and the display connector from the printed circuit board (Fig. 8).
- 8 Undo the battery frame screws (Fig. 9).
- 9 Remove the battery from the appliance and dispose of it according to the rules (Fig. 10).

Operating time



FC6728, FC6725

Using the appliance with Turbo power mode (Setting 2)	20 minutes
Using the appliance with regular power mode (Setting 1)	40 minutes

Troubleshooting

This chapter summarizes the most common problems you could encounter with the appliance. If you are unable to solve the problem with the information below, visit www.philips.com/support for a list of frequently asked questions or contact the Consumer Care Center in your country.

Problem	Possible cause	Solution
The appliance does not work when I push the button.	When the battery is empty, the bottom segment of the display flashes red.	To charge the battery, connect the appliance to the charging station or attach the magnetic charging disc to the charging station directly to the handheld vacuum cleaner.
	You have to push the slider forward to switch on the appliance.	Push the slider forward to setting 1 to switch on. Increase the suction power further by pushing the slider to setting 2 to clean dirty surfaces.
The appliance has a lower suction power than usual.	The filter and the cyclone are dirty.	Clean the filter and the cyclone. Make sure that you wash the sponge filter at least once every two weeks if you use the appliance regularly.
	You have not attached the dust container lid properly to the dust container. You have not attached the dust container to the appliance properly. In both cases, there will be a loss of suction power.	Make sure that you attach the dust container lid to the dust container and the dust container to the appliance properly.
	An object may be stuck inside the tube.	Remove the tube and check for blockages.
Dust escapes from the appliance.	The filter is dirty.	Clean the filter.
	The filter is not present in the appliance.	Make sure that the filter is in the appliance and assembled correctly.
	Something blocks the cyclone.	Check the cyclone for objects stuck in it and remove any object that blocks the cyclone.
	If dust falls out of the dust container, the dust container lid is probably not attached properly to the dust container.	Empty the dust container and attach the dust container lid correctly.
The appliance does not move smoothly across the floor when cleaning a carpet.	You selected a too high suction power.	Reduce the suction power by choosing setting 1.
The brush does not turn anymore.	The brush encounters too much resistance.	Clean the brush with a pair of scissors or by hand.
	The brush may stop turning when it encounters too much resistance from high-pile carpet.	Switch off the appliance and then switch it back on again.
	You have not installed the roller brush in the nozzle properly after cleaning.	Follow the instructions in the cleaning chapter of the user manual to slide the roller brush into the nozzle properly and secure it inside the nozzle by snapping home the locking lever.
The LEDs in the nozzle do not come on.	You have not attached the nozzle to the appliance or handheld properly.	Attach the nozzle to the appliance or handheld properly.
The appliance is not charging.	The magnetic connector is not connected correctly to the charging disk or the adapter is not inserted into the wall socket properly.	Make sure that the magnetic connector is connected properly to the charging disk and that the adapter is inserted into the wall socket properly.
	You have not connected the correct adapter and cord.	Make sure that you use the correct adapter and cord.
		If you have checked the above and the appliance still does not charge, take it to a Philips service center or contact the Consumer Care Center via www.philips.com/support .

Problem	Possible cause	Solution
The mini turbo brush does not function properly.	The roller brush is blocked.	Remove hairs from the brush with a pair of scissors (see user manual).
	The roller brush is blocked by fabric or surfaces during cleaning.	Keep the mini turbo brush aligned with the surface and do not push the turbo brush into soft surfaces.
	The mini turbo brush is not fully closed.	Make sure that the top and bottom parts of the mini turbo brush are properly connected and there is no gap between the two parts. Check if the locking ring is in closed position (see user manual).
When I use my vacuum cleaner I sometimes feel static electricity shocks.	Your vacuum cleaner builds up static electricity. The lower the air humidity, the more static electricity the appliance builds up.	Discharge the appliance by frequently holding the tube against other metal objects in the room (for example the legs of a table or chair, etc.). You can also raise the air humidity level in the room.
	You vacuumed up fine sand, lime or a similar substance. This also causes static electricity.	Empty the dust container and clean the filter according to the instructions in the user manual.
The bottom segment of the display flashes red. 	The battery is empty.	Charge the battery by connecting the appliance to the charging station. You can also charge the appliance directly by inserting the adapter into the wall socket and attaching the magnetic charging disc to the underside of the appliance.
All segments of the display flash quickly. 	An error has occurred.	Check for any blockages in the tube or nozzle. Try recharging the appliance, emptying the dust container and cleaning the filter. If this does not help, take the appliance to a Philips service center or contact the Consumer Care Center via www.philips.com/support .
The middle segment of the display flashes white and the bottom segment of the display flashes red. 	The appliance is stored or charged at temperatures below 5 °C.	Move the appliance to a warmer room. Do not store or charge the appliance at temperatures below 5 °C or above 40 °C.

简体中文

感谢您的惠顾，欢迎使用飞利浦产品！为了您能充分享受飞利浦提供的支持，请在 www.philips.com/MyVacuumCleaner 上注册您的产品。

重要安全信息

使用本产品及其附件之前，请仔细阅读本重要信息，并妥善保管以供日后参考。随附的附件可能因产品而异。

危险

- 切勿吸入水或其他任何液体。切勿吸入易燃物质，也不要吸入未冷却的灰烬。
- 切勿将本产品或适配器浸入水或其他任何液体中，也不要将它们放在水龙头下冲洗。

警告

- 在将本产品连接电源前，务必检查当地的电压是否与电源适配器所标电压一致。
- 使用前，请务必检查产品。如果产品或适配器受损，请停止使用。请务必用原装型号更换损坏的部件。
- 适配器中包含一个变压器。请勿剪下适配器更换其他插头，否则将导致严重后果。
- 产品不建议由有肢体、感官或精神能力缺陷或缺少使用经验和知识的人（包括儿童）使用，除非有负责他们安全的人对他们进行与产品使用有关的监督或指导。
- 请照顾好儿童，本产品不能用于玩耍。
- 务必将磁性充电圆盘放置到儿童接触不到的地方。
- 清洁或维护产品之前，必须先从插座拔掉插头。
- 如果在一段时期内不使用本产品，请拔下适配器插头。
- 将产品存放超过一个月（不使用或不充电）时，请确保电池至少有 50% 的电量。如果在电池电量耗尽的情况下存放产品，可能会对电池造成不可逆的损坏。
- 同时，确保在存放产品时拔下适配器。
- 切勿让电动刷在其它产品的电源线或其它线缆上移动，否则可能会引发危险。
- 确保宽松的衣服、毛发和身体部位远离电动刷。
- 产品运行时，切勿覆盖或堵塞通风口。
- 根据设计，本吸尘器仅限于家用。切勿使用本吸尘器清理建筑垃圾、水泥灰、灰尘、细沙、石灰和类似的物质。切勿在没有任何滤网的情况下使用本吸尘器。这会损坏马达并缩短吸尘器的使用寿命。务必按照用户手册中的说明清洁吸尘器的所有部件。请勿使用水和/或清洁剂清洁任何部件（如果用户手册中未特别说明）。
- 只能用随附的适配器为本产品充电。请仅使用 25V 适配器 ZD12D250050 或 29V 适配器 ZD12D290050。可以在适配器上找到相应的适配器编号。
- 充电、使用和存放本产品的温度应介于 5 °C 至 40 °C 之间。
- 为防止电池发热或释放有毒有害物质，切勿打开、改装、刺穿、损坏或拆卸产品或电池。切勿使电池短路、过度充电或反向充电。
- 请将产品和电池远离火源，切勿将其暴露于阳光直射处或高温下。
- 如果产品异常发热或发出异味、变色或充电时间比平时长，请停止使用并停止为其充电，并联系飞利浦。
- 切勿将产品及其电池放置在微波炉中或电磁炉上。
- 如果电池损坏或出现泄漏，请避免与皮肤或眼睛接触。如果不慎接触，请立即用清水冲洗并就医。
- 本产品包含充电电池。只有具备资格的服务工程师才能更换电池。
- 当充电电池无法继续充电或耗电很快时，请将产品送至授权的飞利浦服务中心。
- 为防止受损，请在集尘桶中放置过滤网后再使用本产品。

注意

- 充电期间，适配器会有微热。这是正常现象。
- 切勿用湿手插入、拔下或操作产品。
- 切勿以拉拔电源线 (图 1) 的方式将适配器从电源插座上拔下。如果没有使用充电座充电，在断开产品的电源连接时，务必先从产品的底部取下磁性充电圆盘 (图 2)。
- 使用后和充电前，请务必关闭产品。
- 吸尘时切勿阻塞排气口。
- 切勿在洗碗机中清洗集尘盒及集尘盒盖。这些部件不可在洗碗机中清洗。
- 务必仅用手每两周至少清洗一次过滤网，以确保实现最佳性能。挤干，直到水干净为止。将过滤网晾干 24 小时，然后再重复使用。
- 请勿使用丝绒型洗刷用具或腐蚀性清洁剂清洁过滤网。
- 使用吸尘器时，请确保装上过滤网。
- 如果用水清洁过滤网，确保其完全干燥后再放回集尘盒中。切勿在直射的阳光下、散热器上或滚筒式烘干机中干燥过滤网。
- 如果无法再洗净过滤网或其已损坏 (请参见 '订购配件')，请予以更换。

- 在安装本产品时，确保按照用户手册中的说明将充电座安装到墙上。
- 在墙上钻孔安装充电座时应多加小心，以防发生触电危险。

电磁场 (EMF)

本 Philips 产品符合所有有关暴露于电磁场的适用标准和法规。

订购配件

如需购买附件或备件，请访问 www.philips.com/parts-and-accessories 或联系您的飞利浦经销商。您还可以联系所在国家/地区的飞利浦客户服务中心（请参阅保修卡了解详细联系信息）。

保修和支持

如需信息或支持，请访问 www.philips.com/support 或阅读保修卡。

回收

- 此符号表示电器产品和电池不能与一般的生活垃圾一同弃置 (图 3)。
- 请遵守您所在国家/地区有关分类回收电器产品和电池的规定。

取出内置充电电池

丢弃产品时，必须仅由有资质的专业人员取出内置充电电池。取出电池之前，请确保产品与电源插座断开连接并且电池电量已完全耗尽。

当您使用工具打开产品时以及在您弃置充电电池时，请采取必要的安全保护措施。

处理电池时，请确保您的双手、产品和电池都是干燥的。

为避免电池拆卸后发生意外短路，切勿让电池端子接触金属物体（例如硬币、发夹、戒指）。切勿用铝箔包裹电池。在丢弃之前，请用胶带将电池端子粘住或将电池放在塑料袋中。

- 1 断开本产品的电源连接并让其继续运行，直至电机停止转动。
- 2 从产品上卸下集尘盒。
- 3 拆下手柄 (图 4) 顶部的显示屏盖。
- 4 拧下手柄盖的螺钉，然后将手柄盖从产品 (图 5) 上取下。
- 5 拧下底盖螺钉 (1)，然后卸下两侧面板。(图 6)
- 6 卸下左侧和右侧的底盖螺钉 (1)。然后卸下底盖 (2) (图 7)。
- 7 从印刷电路板 (图 8) 上断开电池连接器和显示屏连接器。
- 8 拧下电池架螺钉 (图 9)。
- 9 从产品中取出电池并按照规定 (图 10) 处理电池。

工作时间

FC6728、FC6725



在“加速”功率模式下使用 20 分钟
本产品 (设置 2)

在常规功率模式下使用本产品 40 分钟
(设置 1)

故障处理方法

本章归纳了使用本产品时最常见的一些问题。如果您无法根据以下信息解决问题，请访问 www.philips.com/support 查阅常见问题列表，或联系您所在国家/地区的客户服务中心。

问题	可能的原因	解决方法
按下按钮时，产品不工作。	电池电量耗尽时，显示屏底段呈红色闪烁。	为电池充电，做法为将产品连接到充电座上，或将充电座的磁性充电圆盘直接连接到手持式吸尘器上。
	必须向前推动滑块才能打开产品。	将滑块向前推动到设置 1 以打开。将滑块向前推动到设置 2 以进一步增加吸力来清洁脏污表面。
本产品的吸力比往常要小。	过滤网和旋风滤网不干净。	清洁过滤网和旋风滤网。如果您经常使用本产品，请确保每两周至少清洗一次海绵滤网。
	您未将集尘盒盖正确安装到集尘盒上。您未将集尘盒正确安装到产品上。在这两种情况下，吸力将降低。	请确保您将集尘盒盖正确安装到了集尘盒上，并将集尘盒正确安装到了产品上。
	管内可能卡有物体。	取下管件并检查阻塞情况。
灰尘从产品中溢出。	过滤网变脏。	清洁过滤网。
	过滤网未放入产品中。	确保过滤网已放入产品并正确安装。
	污垢堵塞了旋风滤网。	检查旋风滤网是否被物体卡住，并清除任何堵塞旋风滤网的物体。
	如果灰尘从集尘盒中掉出，则集尘盒盖可能未正确安装到集尘盒上。	倒空集尘盒，并正确安装集尘盒盖。
清洁地毯时，产品无法在地板上顺畅移动。	您选择的吸力太大。	通过选择设置 1 来降低吸力。
滚刷不再旋转。	滚刷遇到的阻力太大。	用剪刀或用手清洁滚刷。
	滚刷在长毛绒地毯上遇到太大阻力时，可能会停止转动。	关闭产品，然后将其重新打开。
	您没有在清洗滚刷后将其正确安装到吸嘴上。	请按照本用户手册“清洁”一章中的说明，将滚刷正确滑入吸嘴，并将锁定杆扣合到位，以便将滚刷固定到吸嘴内。
吸嘴中的 LED 指示灯不亮。	您未将吸嘴正确安装到产品上，或未正确手持。	将吸嘴正确安装到产品上，或采用正确的手持方式。
产品未充电。	磁性连接器未正确连接到充电圆盘，或适配器未正确插入电源插座。	请确保磁性连接器正确连接到充电圆盘，且适配器正确插入电源插座。
	您没有连接正确的适配器和电源线。	请确保使用正确的适配器和电源线。

问题	可能的原因	解决方法
		如果已执行上述检查但产品依然无法充电，请将其送至飞利浦维修中心，或通过 www.philips.com/support 联系客服服务中心。
迷你涡轮刷无法正常工作。	滚刷被阻塞。	用剪刀清除刷子上的毛发（请参见用户手册）。
	清洁过程中，滚刷被织物或表面阻塞。	保持迷你涡轮刷与表面对齐，且请勿将涡轮刷推入软质表面。
	迷你涡轮刷未完全关闭。	确保迷你涡轮刷的顶部和底部正确连接，两部分之间没有间隙。检查闭锁环是否处于关闭位置（请参见用户手册）。
有时，在使用吸尘器时会有触静电的感觉。	吸尘器会积聚静电。空气湿度越低，产品积聚的静电就越多。	经常握住硬管使其与房间中的其它金属物体接触（例如，桌椅脚等），对产品进行放电。您也可以增加房间的空气湿度。
	您使用本产品清理细沙、石灰或类似的物质。这还会引发静电。	请清空集尘盒，并按照用户手册中的说明清洁过滤网。
显示屏底段呈红色闪烁。 	电池已耗尽。	将产品连接到充电座为电池充电。您也可以将适配器插入电源插座并将磁性充电圆盘连接到产品的底部来直接为产品充电。
显示屏所有指示段快速闪烁。 	发生错误。	检查管道或吸嘴是否被阻塞。尝试重新为产品充电、清空集尘盒并清洁过滤网。如果这不起作用，可以将产品送至飞利浦维修中心，或通过 www.philips.com/support 联系客服服务中心。
显示屏的中间格段呈白色闪烁，底部格段呈红色闪烁。 	产品存放在 5°C 以下的环境中或在该环境中充电。	将产品移至较暖和的房间。切勿将本产品存放于温度低于 5°C 或高于 40°C 的环境，或在该环境中充电。

PHILIPS

产品：飞利浦手持无绳真空吸尘器
型号：FC6725
额定电压：100V~240V
额定频率：50/60Hz
额定电流：0.5A
生产日期：请见产品底部
产地：中国江苏苏州



飞利浦家电（中国）投资有限公司
上海市静安区灵石路728弄20号201室
全国顾客服务热线：4008 800 008

本产品根据国标 GB4706.1-2005, GB4706.7-2014, GB4343.1-2018及 GB17625.1-2012制造

PHILIPS

产品：飞利浦手持无绳真空吸尘器
型号：FC6728
额定电压：100V~240V
额定频率：50/60Hz
额定电流：0.5A
生产日期：请见产品底部
产地：中国江苏苏州



飞利浦家电（中国）投资有限公司
上海市静安区灵石路728弄20号201室
全国顾客服务热线：4008 800 008

本产品根据国标 GB4706.1-2005, GB4706.7-2014, GB4343.1-2018及 GB17625.1-2012制造

保留备用

发行日期: 15/6/2021