

PHILIPS

DE3203



EN User manual 3

ZH-T 用戶手冊 24



Contents

1 Important	4	6 Cleaning	18
Safety	4	Cleaning the body of the dehumidifier	18
2 Your Air Dehumidifier	8	Cleaning the water tank	18
Product Overview	8	Cleaning the back cover	19
Controls Overview	9	7 Storage	20
3 Getting started	10	8 Troubleshooting	21
Before first use	10	9 Warranty and support	23
Positioning the dehumidifier	10	Order parts or accessories	23
Using the aroma function	10	10 Notices	23
4 Using the dehumidifier	12	Electromagnetic fields (EMF)	23
The humidity light	12	Recycling	23
Turning on and off	12		
Setting the humidity level	13		
Selecting the Auto mode	13		
Changing the fan speed	14		
Selecting laundry drying mode	14		
Using the swing function	14		
Setting the Timer	15		
Defrosting the dehumidifier	15		
Using the light on/off function	16		
5 Draining the dehumidifier	16		
Emptying the water tank	16		
Using the continuous drainage	17		

1 Important

Safety

Read this user manual carefully before you use the dehumidifier, and save it for future reference.

Danger

- Do not spray any flammable materials such as insecticides or fragrance around the dehumidifier to avoid electric shock and/or a fire hazard.
- Do not drink the accumulated water, use it to feed animals, nor to water plants. Empty the water tank, and pour the water down the drain.

Warning

- Check if the voltage indicated on the bottom or indicated at the rear of the appliance corresponds to the local power voltage before you connect the appliance.
- Connect the dehumidifier to the power socket exclusively, and do not connect it through an extension cord to prevent fire hazard and/ or electric shock.

- If the power cord is damaged, you must have it replaced by Philips, a service center authorized by Philips, or similarly qualified persons in order to avoid a hazard.
- Do not use the appliance if the plug, the power cord, or the appliance itself is damaged.
- This appliance can be used by children aged from 8 years and above and persons with reduced physical, sensory or mental capabilities or lack of experience and knowledge if they have been given supervision or instruction concerning use of the appliance in a safe way and understand the hazards involved.
- Cleaning and user maintenance shall not be made by children without supervision
- Do not start or stop the dehumidifier by plugging and unplugging the power cord.
- Do not block the air inlet and outlet, e.g. by placing items on the air outlet or in front of the air inlet.
- Do not insert your fingers or objects into the air

inlet and outlet to prevent physical injury or product malfunction.

- The essential oils are not included with the product. Please purchase and use the essential oils if needed.
- Make sure the product is disconnected with power before dropping essential oils into the aroma box.
- Do not use substances other than essential oils.
- Read and follow the safety and use instruction of the essential oil carefully before using it.
- Check the ingredients information of the essential oil versus your known allergies and exclude it from use when necessary.
- Consult and follow doctor recommendation before using the essential oil for infants, pregnant women or women in the lactation period or if you have respiratory issues.
- If you feel unwell, irritation or discomfort during the use of the essential oil, please stop using it.

Caution

- Do not turn the appliance on and off frequently.
- If the power socket used to power the dehumidifier has poor connections, the plug of the dehumidifier becomes hot. Make sure you plug the dehumidifier into properly connected power socket.
- Always place and use the dehumidifier on a dry, stable, level, and horizontal surface.
- Leave at least 40 cm free space behind and on both sides of the dehumidifier and leave at least 60 cm free space above it. Insufficient ventilation may cause overheating or fire hazard.
- Do not use this dehumidifier when you have used indoor smoke-type insect repellents or in places with oily residues, burning incense, or chemical fumes.
- Do not operate or store the dehumidifier under direct sunlight.
- Do not use the dehumidifier near gas appliances, heating devices or fireplaces.
- Do not use the dehumidifier in a bathroom or other places where it is

likely to come in contact with water, or wash it with water.

- When you use the dehumidifier for drying laundry, hang your clothes from a distance where water droplets will not drip onto the dehumidifier.
- The dehumidifier is only intended for household use under normal operating conditions (5°C - 35°C).
- Do not use the dehumidifier in a room with major temperature changes.
- Run the power cord under carpeting, rugs, or runners. Arrange the cord away from areas where it may be tripped over.
- Make sure the water tank is properly installed before you switch on the dehumidifier.
- Do not touch the swing louver.
- Avoid knocking against the dehumidifier (the air inlet and outlet in particular) with hard objects.
- Always unplug the dehumidifier after use and

before you move or clean it.

- Power off and unplug the dehumidifier before draining the water from the tank. Otherwise, this may result in water leakage or electricity leakage.
- Do not drop the dehumidifier as this may cause personal injury, and damage to the floor or household items as a result of water spillage.
- Do not place anything on top of the dehumidifier.
- Do not stand on, sit on, or lean against the dehumidifier. This may cause the dehumidifier to tip over causing injury.
- Do not remove or dismantle the float in the tank; otherwise, the dehumidifier cannot detect when the tank is full and could result in water leakage.
- Do not use detergents, cleaning agents, abrasive powders, chemically treated dusters, gasoline, benzene, thinners or other solvents, as they can damage the dehumidifier or the water tank. This may result in water leakage.

- Mildew may form in the water tank, clean it every week with tap water. Then, wipe with a soft, dry cloth.
- If you do not use the dehumidifier for an extended period of time, make sure all parts are clean and dry.
- Do not use the dehumidifier for food preservation, art or scientific works.
- Do not point the airflow of the dehumidifier directly at the body for a prolonged period of time, especially where there is someone who is unable to use the humidity adjustment function. For instance: infant, child, or elderly person. This may harm the physical condition and lead to dehydration.
- Use the dehumidifier with cautions where the walls, furniture, and art works are vulnerable to dry air.
- Do not place the appliance directly below an air conditioner to prevent condensation from dripping onto the appliance which will cause short circuit and leakage of electricity.
- Do not use the dehumidifier in a room with major temperature changes, as this may cause condensation inside the dehumidifier.
- To prevent interference, place the appliance at least 2m away from electrical appliances that use airborne radio waves such as TVs, radios, and radio-controlled clocks.
- The appliance does not remove carbon monoxide (CO) or radon (Rn). It cannot be used a safety device in case of accidents with combustion processes and hazardous chemicals.
- Never move the appliance by pulling the power cord.
- This appliance is not a substitute for proper ventilation, regular vacuum cleaning, or use of an extractor hood or fan while cooking.
- Do not sit or stand on the appliance. The appliance is equipped with omni wheels. Sitting or standing on the appliance may lead to potential injury.

Fuse Specification:

T1.6A 250V~

T5.0A 250V~

2 Your Air Dehumidifier

Congratulations on your purchase, and welcome to Philips!

To fully benefit from the support that Philips offers, register your product at www.Philips.com/welcome.

Product Overview

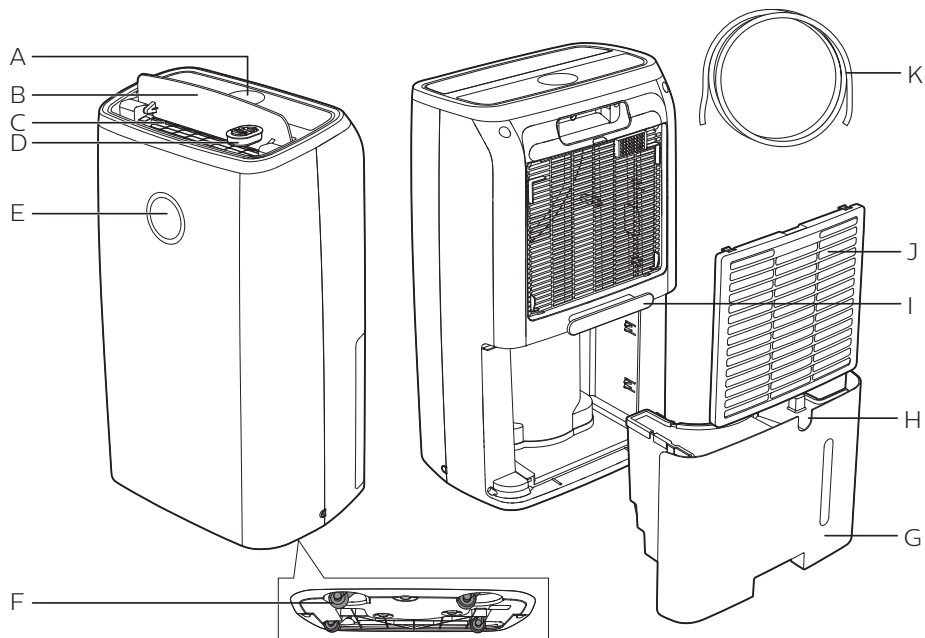

A	Display panel	G	Water tank
B	Louver	H	Continuous drainage outlet
C	Air outlet	I	Power cord wrapping handle
D	Aroma box	J	Back cover
E	Humidity indication light	K	Hose
F	Omni wheels		

Controls Overview

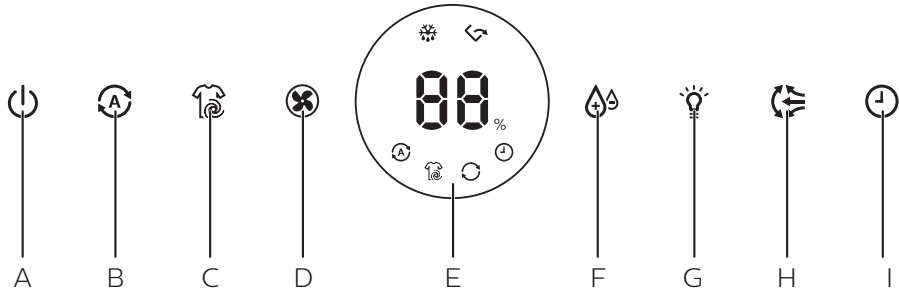

A	On/off button	F	Humidity setting button
B	Auto mode button	G	Light on/off button
C	Laundry drying mode button	H	Auto swing button
D	Fan speed button	I	Timer button
E	Display screen		

Display panel

	Auto defrosting indicator		Laundry drying mode icon
	Water tank full alert		Continuous mode icon
	Auto mode icon		Timer indicator

3 Getting started

Before first use

Before using the appliance, remove all packaging materials.

Note

- Before using the dehumidifier, place it horizontally.

Positioning the dehumidifier

To increase the dehumidifying effectiveness, position the dehumidifier in a location that can draw the most air.

Note

- When the dehumidifier is operating, do not open exterior doors or windows.

Using the aroma function

Note

- Only the aroma box is provided, the essential oils are not included with the product. Please purchase and use the essential oils if needed.
- Make sure the product is disconnected with power before dropping essential oils into the aroma box.
- Do not use substances other than essential oils.
- Read and follow the safety and use instruction of the essential oil carefully before using it.
- Check the ingredients information of the essential oil versus your known allergies and exclude it from use when necessary.
- Consult and follow doctor recommendation before using the essential oil for infants, pregnant women or women in the lactation period or if you have respiratory issues.
- If you feel unwell, irritation or discomfort during the use of the essential oil, please stop using it.

- 1 Remove the aroma box from the top of the appliance.

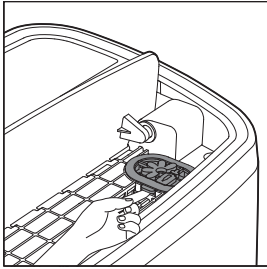

2 Remove the cover of the aroma box.

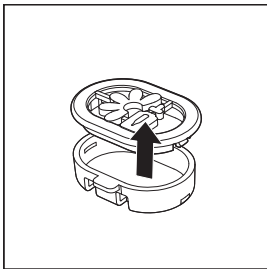

3 Remove the packing materials of the aroma pads and put one piece of pads into aroma box.

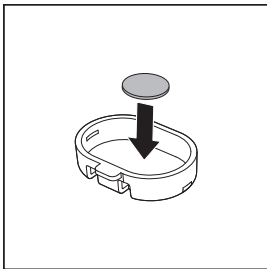

4 Drop in 2-3 drops of essential oils to the aroma pad.

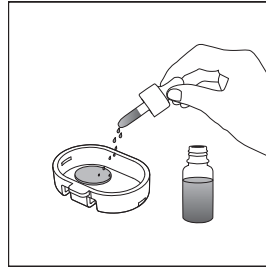

5 Close the cover of the aroma box and put it back onto the top of the dehumidifier.

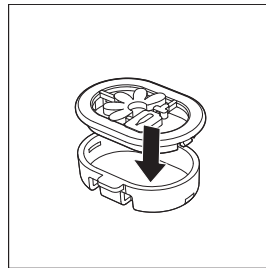

4 Using the dehumidifier

The humidity light



Humidity light color	Ambient humidity level
Blue	≤5 (Lower ambient humidity level compared with preset humidity level)
Purple	6-15 (Medium ambient humidity level compared with preset humidity level)
Red	>15 (Higher ambient humidity level compared with preset humidity level)

The humidity light automatically goes on when the appliance is switched on, and lights up all colors in sequence. In a short time the humidity sensors select the color that corresponds to the surrounding humidity.

Turning on and off

Note

- For optimum performance, close doors and windows.
- Keep curtains away from the air inlet or air outlet.
- For optimum dehumidification efficiency, place the dehumidifier in a flat, stable surface.
- Before turning on the dehumidifier, check if the power voltage corresponds to the voltage printed on the dehumidifier.

- 1 Put the plug of the dehumidifier in the wall outlet.
↳ The dehumidifier beeps.
- 2 Touch the  button once to turn on the appliance.
↳ The current humidity level is displayed on the screen.
↳ After measuring the ambient humidity level, the humidity sensor automatically selects the color of the humidity light.
↳ The dehumidifier goes to the Auto mode.
- 3 Touch and hold  for 3 seconds to turn off the dehumidifier.

Setting the humidity level

You can set the desired humidity level to **40, 50, 60, 70**, or **--** percent.

- Touch the  button one or more times to set the desired humidity level, and the humidity indicator lights up.

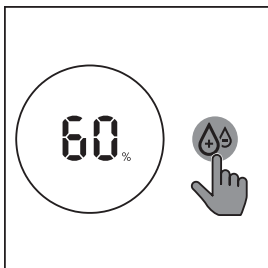

Note



- When the humidity is decreased to the selected level, the dehumidifier automatically stops dehumidifying the air, but the fan will continue working.
- If you do not set the humidity level, the default relative humidity is 60%.

Tip

- A comfortable humidity level is from RH 40% to RH 60%.



Continuous mode

In continuous  mode, the appliance constantly works with the optimal dehumidifying settings.

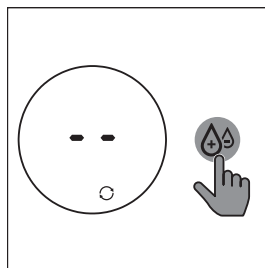
- Touch the  button repeatedly to select the continuous mode.
 - ↳ The **--** and  display on the screen.



Selecting the Auto mode

- Touch the Auto mode button  to select the Auto mode.
 - ↳  displays on the screen.
 - ↳ The current humidity level displays on the screen.

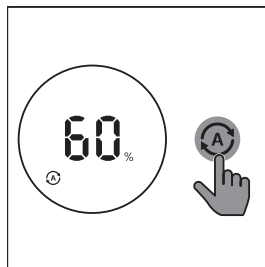

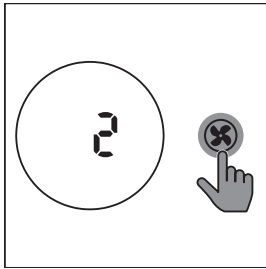

Changing the fan speed

- Touch the fan speed button  repeatedly to select the fan speed (1, 2 or 3) you need.



Selecting laundry drying mode

- Touch the  button to select the laundry drying mode.
 - ↳ The dehumidifier goes to laundry drying mode.
 - ↳ The dehumidifier operates under the highest fan speed.
 - ↳  display on the screen.

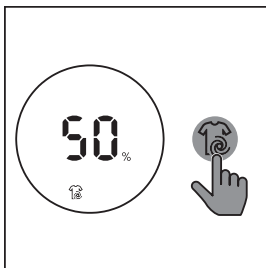

Note

- Do not point the airflow of the dehumidifier directly at the body for a prolonged period of time, especially where there is someone who is unable to use the humidity adjustment function.
- When you use the dehumidifier for laundry drying, hang your clothes from a distance where water droplets will not drip onto the dehumidifier.
- Make sure the air inlet and outlet are not blocked by the clothes.
- Make sure that you dry the clothes on a safe and secure place from dropping to block the air inlet and outlet.

Tip

- Direct the louver until air flows directly onto the clothes to dry your clothes more efficiently.

Using the swing function

The louver is able to swing close to 90 degrees. Use the swing function to direct the air flow.

- 1 Touch the  button to activate the swing function.

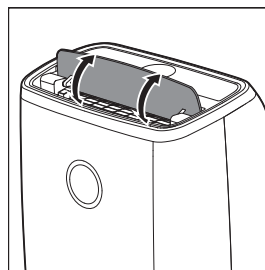

- 2 Touch the  button again to deactivate the swing function.

Tip



- After the appliance is turned on, turn the louver upward to increase the dehumidifying efficiency.

Setting the Timer

With the timer function, you can let the dehumidifier operate for a set number of hours. When the set time has elapsed, the dehumidifier automatically turns off. The timer is available from 1 to 9 hours.

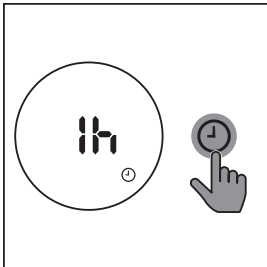
- 1 Touch the  button to activate the timer.



- 2 Touch the  button repeatedly to choose the number of hours you want the dehumidifier to operate .
 - To deactivate the timer function, touch the  button repeatedly until **--** is displayed on the screen.

Defrosting the dehumidifier

Note

- The defrosting function is enabled only when the dehumidifier operates under dehumidifying mode.

The dehumidifier is equipped with a defrosting sensor to make sure it is in optimal condition when being used in cold weather. The dehumidifier automatically detects if defrosting is required.

When defrosting is required:

- ↳ The  indicator is on.
- ↳ Defrosting will begin and continue until the dehumidifier is completely defrosted.

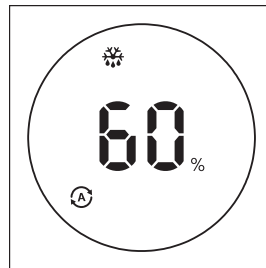



☰ Note

- During defrosting, the dehumidifier operates in clothes dry mode.
- The dehumidifier will resume working and operate the previous settings after defrosting is completed.

Using the light on/off function

With the light on/off button, you can switch on or off the humidity light or the display screen.

- 1 Touch the light on/off button  once, the humidity light will go off.
- 2 Touch the light on/off button  again, the display screen will dimmed.
- 3 Touch the light on/off button  for the third time, all lights will be on again.

5 Draining the dehumidifier

Emptying the water tank

When the water tank is full:

- ↳ The appliance beeps, and the  indicator is on.

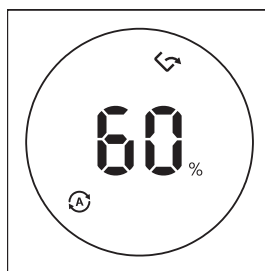

- 1 Hold the recess of the water tank, and pull it from the dehumidifier.

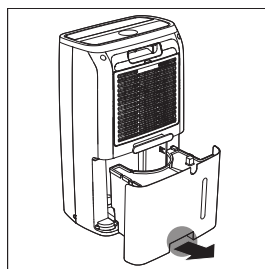

- 2** Open the water tank cover and empty the water into a sink.

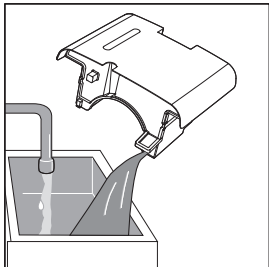

- 3** Wipe the outside of the water tank dry with a clean cloth.

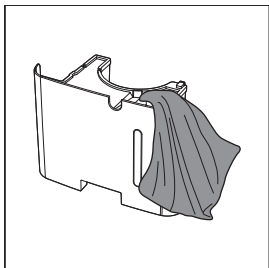

- 4** Put the water tank back into the dehumidifier.

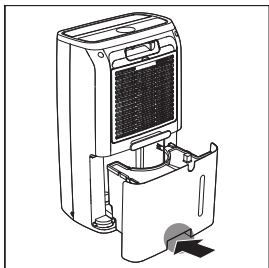

Note

- The dehumidifier will resume working after the water tank is emptied.

Using the continuous drainage

The dehumidifier can also drain excess water by attaching a hose. This allows you to operate the dehumidifier without emptying the water tank.

- 1** Turn off the dehumidifier and unplug from the wall socket.
- 2** Remove the water tank from the dehumidifier.

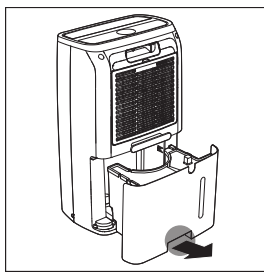

- 3** Connect the hose to the drainage outlet.

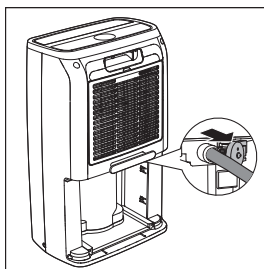

- 4 Put the water tank back into the dehumidifier.

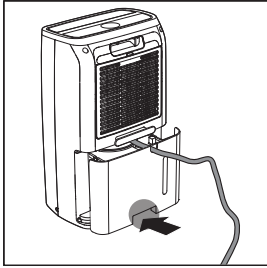

Note

- Put the water tank back in to the dehumidifier even using the continuous drainage, or the dehumidifier can not operate normally.
- Make sure the hose fits tightly so that no water leaks from the dehumidifier.
- When using the continuous drainage, make sure the hose is laid flat and not knotted.
- Make sure the hose is not immersed in water, nor raised higher than the continuous drainage hole.
- Place the outlet of the hose in somewhere it can easily drain.
- Check the dehumidifier once a week when draining water continuously or left unattended for an extended period of time.

6 Cleaning

Note

- Always turn the appliance off and unplug the appliance from the electrical outlet before cleaning.
- Never immerse the appliance in water or any other liquid.
- Never use abrasive or aggressive cleaning agents such as bleach or alcohol to clean any part of the appliance.
- The back cover is washable.

Cleaning the body of the dehumidifier

Regularly clean the inside and outside of the dehumidifier to prevent dust from collecting.

- 1 Use a soft, dry cloth to clean both the interior and exterior of the appliance.
- 2 The air outlet can also be cleaned with a dry, soft cloth.

Cleaning the water tank

Clean the water tank every day to keep it clean.

- 1 Switch off the dehumidifier and unplug from the electrical outlet.

- 2 Remove the water tank from the dehumidifier.

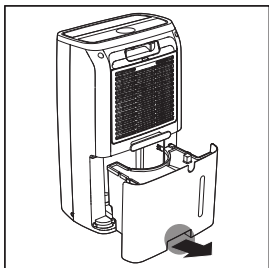

- 3 Open the water tank cover and fill the water tank for 1/3 with water.

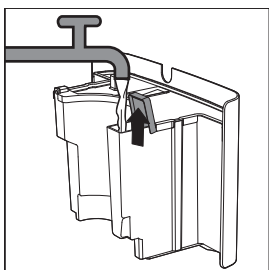

- 4 Add some mild washing-up liquid to the water in the water tank.

- 5 Wash the water tank under a running tap water, and clean the insides of it with a soft clean cloth.

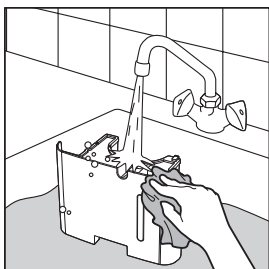

- 6 Wipe the outside of the water tank dry with a clean cloth.

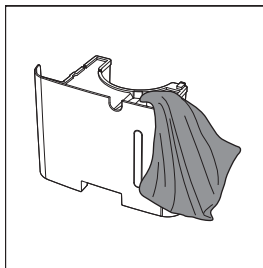

- 7 Put the water tank back into the dehumidifier.

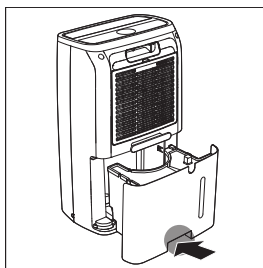

Cleaning the back cover

Clean the back cover when necessary to keep it clean.

Note

- The back cover is washable and vacuum cleanable.

- 1 Switch off the dehumidifier and unplug from the electrical outlet.

- 2 Pull the back cover, and remove it from the dehumidifier.

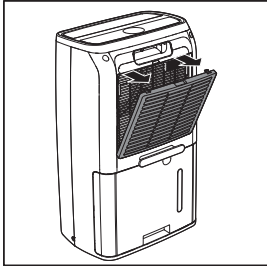

- 3 If the back cover is very dirty, use a soft brush to brush away the dust. Wash the back cover under a running tap water.

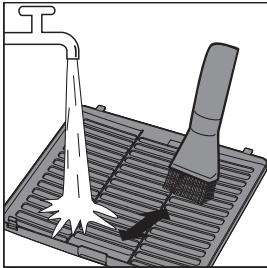

- 4 Allow the back cover to air dry thoroughly before placing back in the dehumidifier.
- 5 Put the back cover back into the appliance.

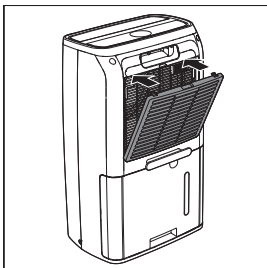

- 6 Put the plug of the dehumidifier in the wall outlet.
- 7 Wash your hands thoroughly after cleaning the back cover.

7 Storage

- 1 Turn off the dehumidifier and unplug from the wall outlet.
- 2 Clean the dehumidifier, empty the water tank and wash the back cover (see chapter 'Cleaning').
- 3 Let all parts dry thoroughly before storing.
- 4 Store the dehumidifier in a cool, dry location.

8 Troubleshooting

This chapter summarizes the most common problems you could encounter with the dehumidifier. If you are unable to solve the problem with the information below, visit www.philips.com/support or contact the Consumer Care Center in your country for assistance.

Problem	Possible solution
The appliance does not work even though it is plugged in to the wall socket and switched on.	<ul style="list-style-type: none"> • The timer is set to a specific time interval. Reset or turn off the timer. • Try a different electrical socket or check the wall switch. • Make sure that the water tank is empty and placed in the dehumidifier properly.
The water tank is empty but the  indicator is still on.	<ul style="list-style-type: none"> • Remove the water tank from the dehumidifier and place it back to the dehumidifier again.
There is no air dehumidification in the room or the dehumidifying effectiveness is low.	<ul style="list-style-type: none"> • Make sure the air inlet and outlet are not blocked. • The room humidity is below what the dehumidifier is set to. Select a lower humidity level. • Make sure that no exterior doors or windows are open. • The current temperature is low in the room. Try again until the temperature rises up.
Water leaks from the dehumidifier.	<ul style="list-style-type: none"> • Make sure that the dehumidifier is in good condition and the water tank is not cracked.
The dehumidifier does not collect water.	<ul style="list-style-type: none"> • The humidity is low. The dehumidifier automatically resumes working when the humidity level is increased. • The temperature is low. Wait until the temperature rises up.

Problem	Possible solution
The airflow that comes out of the air outlet is significantly weaker than before.	<ul style="list-style-type: none"> • The back cover is dirty. Clean the back cover (see chapter "Cleaning").
The dehumidifier produces a unpleasant smell.	<ul style="list-style-type: none"> • The first few times you use the dehumidifier, it may produce a plastic smell. This is normal. • If the dehumidifier produces a burnt odor, switch OFF and unplug from the electrical outlet. Contact the Consumer Care Center in your country for assistance.
The dehumidifier is loud.	<ul style="list-style-type: none"> • If the dehumidifier is too loud, change the fan speed to a lower fan speed level. When using the product in a bedroom at night, choose a lower fan speed. • Make sure that the dehumidifier is placed on a flat and stable surface.
Error codes "E3" "E4" or "E5" displays on the screen.	<ul style="list-style-type: none"> • The dehumidifier has malfunctions. Contact the Consumer Care Center in your country.

9 Warranty and support

Versuni offers a two-year warranty after purchase on this product. This warranty is not valid if a defect is due to incorrect use or poor maintenance. Our warranty does not affect your rights under law as a consumer. For more information or for invoking the warranty, please visit our website www.philips.com/support.

Order parts or accessories

If you have to replace a part or want to purchase an additional part, go to your Philips dealer or visit www.philips.com/support.

If you have problems obtaining the parts, please contact the Philips Consumer Care Center in your country.

10 Notices

Electromagnetic fields (EMF)

This appliance complies with the applicable standards and regulations regarding exposure to electromagnetic fields.

Recycling

Do not throw away the product with the normal household waste at the end of its life, but hand it in at an official collection point for recycling. By doing this, you help to preserve the environment.

Follow your country's rules for the separate collection of electrical and electronic products. Correct disposal helps prevent negative consequences for the environment and human health.

目錄

1 重要事項	25	7 存放	39
安全性注意事項	25		
2 您的空氣抽濕機	28	8 疑難排解	40
產品概要	28		
控制鍵概覽	29	9 保固與支援	41
		訂購零件或配件	41
3 使用入門	30	10 注意	41
首次使用前	30	電磁場 (EMF)	41
放置抽濕機	30	回收	41
使用芬香功能	30		
4 使用抽濕機	31		
濕度指示燈	31		
開關	31		
設定濕度	32		
選擇自動模式	32		
改變風扇速度	33		
選擇乾衣模式	33		
使用旋轉功能	33		
設定定時功能	34		
抽濕機除霜	34		
使用開燈/關燈功能	34		
5 替抽濕機排水	35		
清空水箱	35		
使用持續排水功能	36		
6 清潔	37		
清潔抽濕機機身	37		
清潔水箱	37		
清潔後蓋	38		

1 重要事項

安全性注意事項

使用抽濕機前，請認真閱讀本用戶手冊，並保管以作將來參考。

危險事項

- 請勿在抽濕機周圍噴射殺蟲劑或芳香劑等易燃物品，以避免觸電及/或火災。
- 請勿飲用積水、用於餵飼動物及澆花。清空水箱，再將水倒進排水管。

警告

- 在連接產品前，請檢查顯示於產品側面或下方的電壓是否與您當地的電壓相符。
- 將抽濕機接駁到獨立的電源插座，請勿使用延長線進行連接，以免引發火災及/或觸電。
- 如果電源線損壞，為避免危險，必須由 Philips、Philips 授權的服務中心或類似的合資格人士來更換。
- 若插頭、電源線或產品本身已受損，請勿使用。
- 此產品可供八歲及以上兒童，體能、感官或心智能力低下人士，或缺乏知識及經驗人士使用，如該等人仕已就使用本產品給予監督或有

關安全使用本產品的指導及明白本產品的使用所涉及的危險。

- 兒童不應於沒有監督情況下對產品進行清潔及維護。
- 請勿透過插入及拔下電源線的方式啟動或停止抽濕機的運作。
- 請勿阻塞通風口和排氣口，如在排氣口上或通風口前放置物品。
- 請勿將手指或物件插入進氣口及排氣口，以免造成身體傷害或產品故障。
- 產品未隨附精油。如有需要，請自行購買及使用精油。
- 將精油倒入芬香盒前，確認產品已中斷電源連接。
- 請勿使用精油以外的物質。
- 使用精油前，請仔細閱讀並遵守其安全及使用說明。
- 請針對您已知的致敏原檢查精油的成分資訊，必要時請勿使用。
- 對嬰兒、孕婦、哺乳期女性使用精油，或如您有呼吸問題，請先諮詢並遵守醫生建議。
- 如您在使用精油時感到不適、刺激或不舒服，請停止使用。

注意

- 請勿頻繁開關本產品。
- 若為抽濕機提供電力的電源插座沒有妥善連接，抽濕機的插頭便會發熱。確保將抽濕機插入妥善連接的電源插座。
- 在乾爽、穩定、平坦而水平表面上使用抽濕機。
- 在抽濕機兩側及後方保留 40 厘米的空間，以及在抽濕機上方保留 60 厘米的空間。空氣不流通可能導致過熱或火災。
- 若您使用室內煙型驅蚊劑，或該地方有油跡、香火或化學煙霧，請勿使用抽濕機。
- 請勿在陽光直射下操作或存放抽濕機。
- 請勿在煤氣用具、暖氣設備或壁爐旁邊使用抽濕機。
- 請勿在浴室或可能接觸到水的地方使用抽濕機，也不可用水清洗。
- 當使用抽濕機乾衣，將衣物掛起時應保持一定的距離，使水滴不會滴入抽濕機裡。
- 抽濕機只適合家居使用及在一般運作情況下使用 (5°C - 35°C)。
- 請勿在溫差很大的房間內使用抽濕機。
- 在地毯、小地毯或滑槽下鋪好電源線。妥善鋪設電源線，以防絆倒。
- 開啟抽濕機前，請確保水箱已妥善安裝。
- 請勿接觸旋轉百葉送風口。
- 避免以硬物碰撞抽濕機（尤其是通風口和排氣口）。
- 使用後，以及移動或清潔抽濕機前，必須拔除抽濕機的插頭。
- 先關閉並拔除抽濕機的插頭，再將水箱的水排走。否則可能導致漏水或漏電。
- 請勿摔落抽濕機，否則可能導致人身受傷，以及因濺水而對地板或家居用品造成損毀。
- 請勿在抽濕機上放置任何物品。
- 請勿站在或坐在抽濕機上，也不可倚靠抽濕機。否則可能導致抽濕機傾側翻轉，引致受傷。
- 請勿移除或拆下水箱的浮標，否則抽濕機無法偵測到水箱已滿，因而導致漏水。
- 請勿使用洗潔劑、清潔劑、磨蝕粉、經過化學處理的除塵劑、汽油、苯、稀釋劑或其他溶劑，因為這些物品會令抽濕機或水箱損毀。這樣可能導致漏水。

- 霉菌可能在水箱內形成，因此每星期應使用自來水進行清潔。然後用柔軟的乾布擦拭。
- 如果您長時間沒有使用抽濕機，確保所有部件清潔乾爽。
- 請勿使用抽濕機作保存食物、藝術或科學之用。
- 請勿將抽濕機的氣流長時間直接指向身體，特別是無法使用濕度調整功能的人士。例如：嬰兒、兒童或長者。這樣可能會傷害身體，引致出現缺水的情況。
- 在牆壁、傢俱及藝術品附近使用抽濕機要格外留神，因為乾的空氣容易令這些物品受損。
- 請勿將本產品直接放置於冷氣機下，以防止凝結水滴進本產品內，這樣會造成短路及漏電。
- 請勿在溫差很大的房間內使用抽濕機，這樣可能會導致抽濕機內凝結水滴。
- 為了防止干擾，請與使用空中無線電波的電器距離 2 米的地方使用本產品。
- 本產品不會去除一氧化碳 (CO) 或氫 (Rn)。本產品不能

在含有燃燒過程和危險化學品的意外中充當安全裝置。

- 請勿拉扯電源線來移動本產品。
- 本產品並不是適當通風設備、正規吸塵器或煮食時使用的抽油煙機或風扇的代替品。
- 請勿坐或站立在裝置上。裝置設有全方位輪。坐在或站立在裝置上可能會導致受傷。

保險絲規格：

T1.6A 250V~

T5.0A 250V~

2 您的空氣抽濕機

感謝您購買 Philips 產品，歡迎來到 Philips 世界！

要享受 Philips 為您提供的全面支援，請在以下網站 www.Philips.com/welcome 註冊您的產品。

產品概要

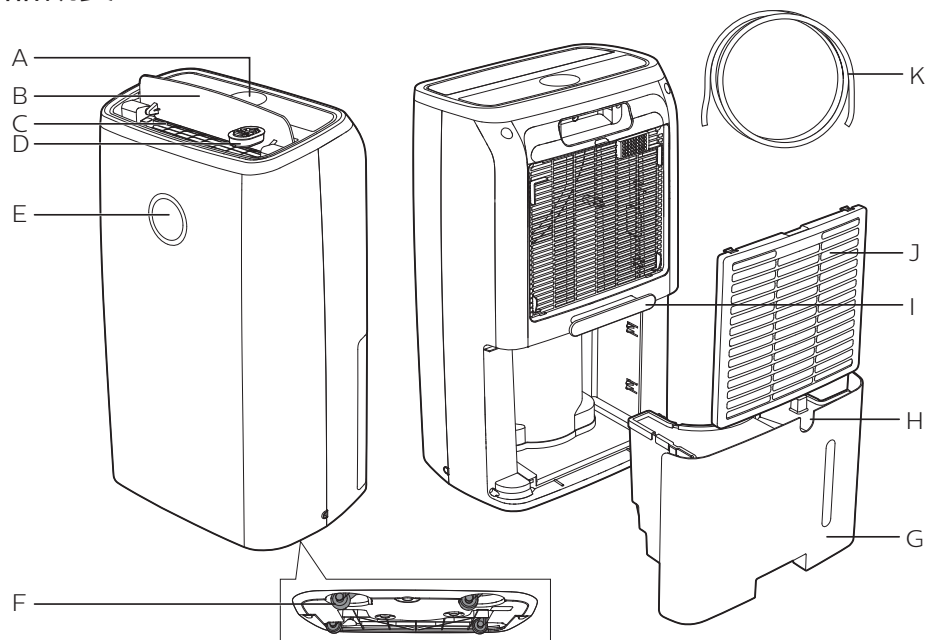

A	顯示面板	G	水箱
B	送風葉片	H	持續排水口
C	送風口	I	電源線收藏把手
D	芬香盒	J	後蓋
E	濕度指示燈	K	軟管
F	全向輪		

控制鍵概覽

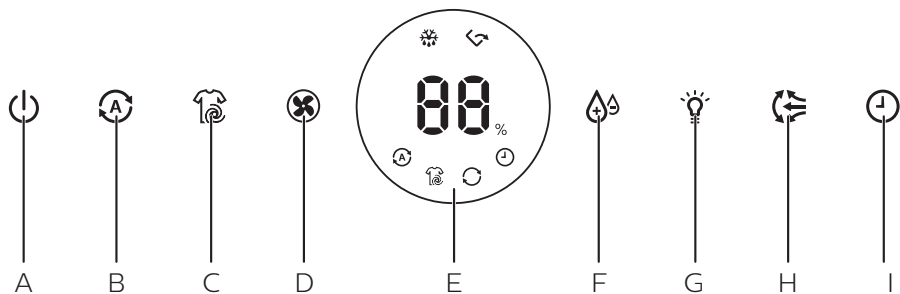

A	開/關按鈕	F	濕度設定按鈕
B	自動模式按鈕	G	開燈/關燈按鈕
C	乾衣模式按鈕	H	自動搖擺按鈕
D	風速按鈕	I	定時功能按鈕
E	顯示屏幕		

顯示面板

	自動除霜提示		乾衣模式圖標
	水箱滿水警報		持續抽濕模式圖標
	自動模式圖標		定時功能指示燈

3 使用入門

首次使用前

使用產品前，請先移除所有包裝物料。

注意

- 使用抽濕機前，請將其水平放置。

放置抽濕機

為了增加抽濕的效果，將抽濕機擺放在可以抽入最多空氣的位置。

注意

- 當抽濕機操作時，請勿打開外門或窗戶。

使用芬香功能

注意

- 產品只有附送芬香盒，產品未隨附精油。如有需要，請自行購買及使用精油。
- 將精油倒入芬香盒前，確認產品已中斷電源連接。
- 請勿使用精油以外的物質。
- 使用精油前，請仔細閱讀並遵守其安全及使用說明。
- 請針對您已知的致敏原檢查精油的成分資訊，必要時請勿使用。
- 對嬰兒、孕婦、哺乳期女性使用精油，或如您有呼吸問題，請先諮詢並遵守醫生建議。
- 如您在使用精油時感到不適、刺激或不舒服，請停止使用。

- 1 將芬香盒由產品頂部拆下。

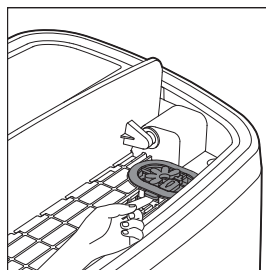

- 2 移除芬香盒的護蓋。

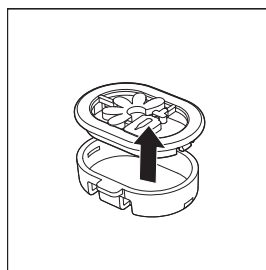

- 3 拆除芳香墊的包裝物料，將一塊芳香墊放入芳香盒中。

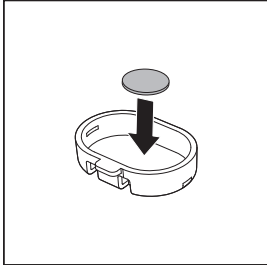

- 4 將 2-3 滴精油滴到芳香墊上。

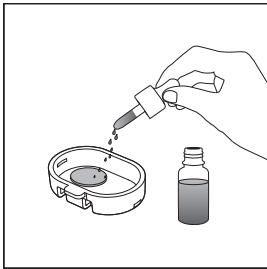

- 5 關上芳香盒的護蓋，再放回抽濕機頂部。

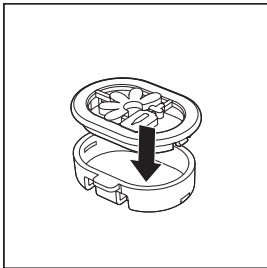

4 使用抽濕機

濕度指示燈



濕度指示燈顏色	環境濕度水平
藍色	≤5 (環境濕度水平比現時濕度要低)
紫色	6-15 (環境濕度水平與現時濕度相若)
紅色	>15 (環境濕度水平比現時濕度要高)

開啟產品後，濕度指示燈會自動亮起，並順序顯示所有顏色。只要稍等片刻，濕度感應器就會選擇與環境濕度水平相符的顏色。

開關

注意

- 請關閉門窗，以獲得最佳效果。
- 窗簾必須遠離進氣口或排氣口。
- 請將抽濕機放置於平坦的表面上，以獲得最佳的抽濕效果。
- 開啟抽濕機前，請檢查電源電壓與抽濕機上列印的電壓是否對應。

- 1 將抽濕機的插頭插入牆身插座。
↳ 抽濕機響起嗶聲。
- 2 按一次  按鈕，即可啟動產品。
↳ 螢幕顯示目前的濕度。
↳ 測量環境濕度水平後，濕度感應器會自動選擇濕度指示燈的顏色。
↳ 抽濕機進入自動模式。
- 3 按住  3 秒以關閉抽濕機。

設定濕度

您可將所需濕度設為 40、50、60、70 或 --%。

- 按一次或多次  按鈕設定所需濕度，濕度指示燈就會隨之亮起。

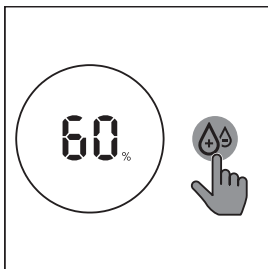

注意

- 當濕度下降至所選程度，抽濕機自動停止將空氣抽濕，但風扇將會繼續運作。
- 如果您沒有設定濕度，預設相對濕度將為 60%。

貼士

- 舒適濕度水平介乎相對濕度 40% 至 60% 之間。

連續模式：

本產品在連續  模式下，將根據最適當的抽濕設定持續運作。

- 重複按下  按鈕，以選擇連續模式。

↳ 螢幕顯示 -- 及 .

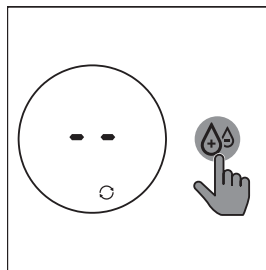

選擇自動模式

- 按下自動模式按鈕 ，即可選擇自動模式。

↳  將會顯示在螢幕上。

↳ 螢幕顯示目前的濕度水平。

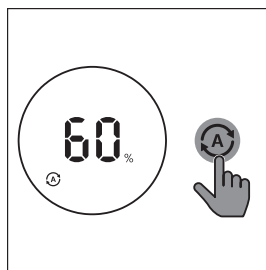

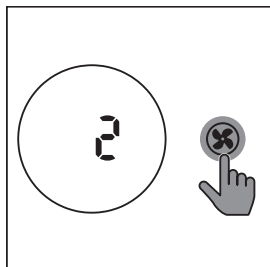

改變風扇速度

- 重複按下風扇速度按鈕 ，即可按需要選擇風扇速度（1、2 或 3）。



選擇乾衣模式

- 按  按鈕選擇乾衣模式。
 - ↳ 抽濕機進入乾衣模式。
 - ↳ 抽濕機以最高風扇速度運作。
 - ↳ 螢幕顯示 。

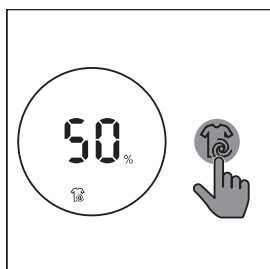

注意

- 請勿將抽濕機的氣流長時間直接指向身體，特別是無法使用濕度調整功能的人士。
- 當使用抽濕機乾衣，將衣物掛起時應保持一定的距離，使水滴不會滴入抽濕機裡。
- 確保進氣口及排氣口沒有受到衣物阻塞。
- 請在安全穩妥的地方乾衣，確保水滴不會滴入進氣口和排氣口。

貼士

- 調整送風葉片，讓風直接吹在衣服上，就可更加有效乾衣。

使用旋轉功能

送風葉片可以旋轉接近 90 度。使用旋轉功能引導氣流。

- 1 按  按鈕可啟動旋轉功能。

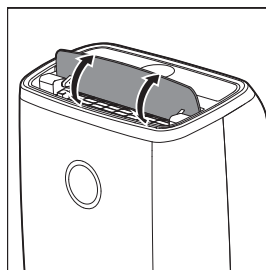

- 2 再按下  按鈕可停用旋轉功能。

貼士



- 啟動本產品後，請將送風葉片調向上方，以改善抽濕效果。

設定定時功能

透過定時功能，您可以讓抽濕機在設定的時數內運作。設定時間過去之後，抽濕機會自動關閉。定時功能的選擇為1至9個小時。

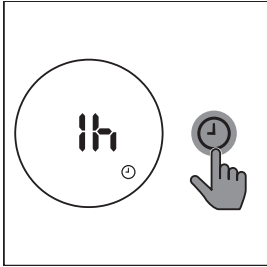
1 按  按鈕啟動定時功能。



2 重複按下  按鈕，選擇抽濕機運作的所需時數。
• 如要停用定時功能，請重複按下  按鈕，直至螢幕顯示 --。

抽濕機除霜

注意

- 抽濕機僅可於抽濕模式時啟用除霜功能。

抽濕機備有解凍感應器，確保在寒冷的天氣下仍以最佳的狀態運作。抽濕機自動偵測需否進行解凍程序。

需要解凍時：

- ↳  指示燈會亮起。
- ↳ 除霜程序將會進行，直至抽濕機完全除霜。

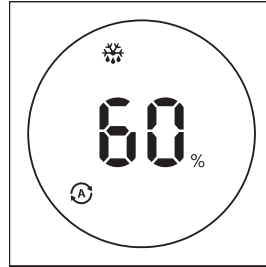



注意

- 在除霜過程中，抽濕機將以乾衣模式運行。
- 除霜完成後，抽濕機將會以先前設定繼續運作。

使用開燈/關燈功能

使用開燈/關燈按鈕，便可開啟或關閉濕度指示燈和顯示畫面。

- 1 按下開燈/關燈按鈕  一次，濕度指示燈就會熄滅。
- 2 再次按下開燈/關燈  按鈕，顯示畫面就會變暗。
- 3 第三次按下開燈/關燈按鈕 ，所有燈將會再次亮起。

5 替抽濕機排水

清空水箱

當水箱已滿：

↳ 本產品發出嗶聲，↶指示燈發亮。

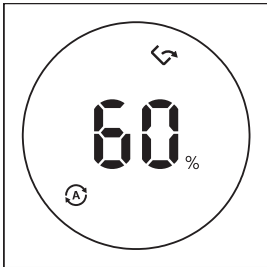

- 1 握著水箱凹槽位置，將其從抽濕機卸下。

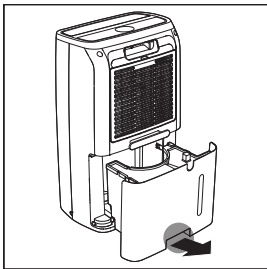

- 2 打開水箱護蓋，再將水倒進洗手盆。

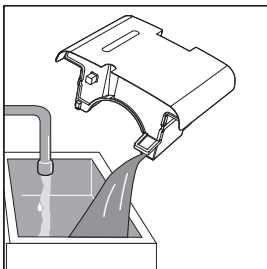

- 3 用清潔的布將水箱的外部擦乾。

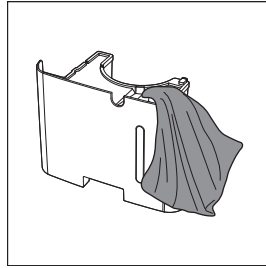

- 4 將水箱放回抽濕機。

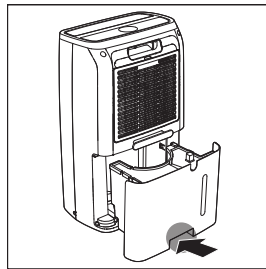

注意

- 清空水箱後，抽濕機將會繼續運作。

使用持續排水功能

抽濕機可裝上軟管將多餘的水排走。此功能讓抽濕機保持運作，而無需為水箱排水。

- 1 關閉抽濕機，並將插頭從電源插座拔出。
- 2 從抽濕機取出水箱。

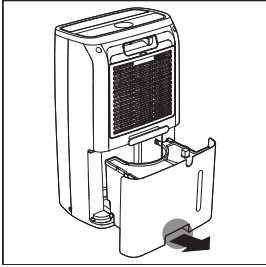

- 3 將軟管接駁到排水口。

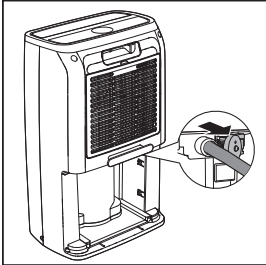

- 4 將水箱放回抽濕機。

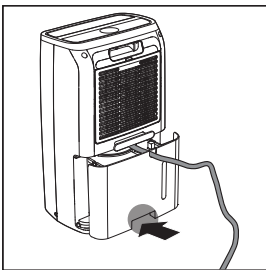

注意

- 即使使用持續排水功能，亦必須將水箱放回至抽濕機，否則抽濕機便不能正常運作。
- 確保軟管緊密貼合，沒有水從抽濕機漏出。
- 使用持續排水時，確保平放軟管，沒有打結。
- 確保軟管沒有浸入水裡，且不是放在高於持續排水孔的位置。
- 將喉管的出口放置在易於排水的地方。
- 使用持續排水或長時間閒置不用時，應每星期檢查抽濕機一次。

6 清潔

注意

- 進行清潔前，必須關閉本產品，並將產品從電源插座拔除。
- 切勿將本產品侵入水中或任何其他液體中。
- 切勿使用磨蝕性或刺激性清潔劑（如漂白劑或酒精）清洗本產品的任何一部分。
- 後蓋可以清洗。

清潔抽濕機機身

請定時清潔抽濕機的內外，以避免機身積聚塵埃。

- 1 使用柔軟乾爽的抹布清潔本產品的內部和外部。
- 2 排氣口亦可以柔軟乾爽的抹布清潔。

清潔水箱

請每日清理水箱以保持清潔。

- 1 關閉抽濕機，並將其從電源插座拔出。
- 2 從抽濕機取出水箱。

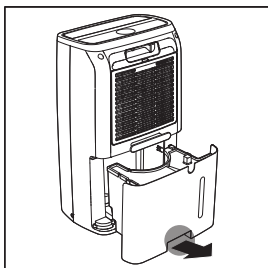

- 3 打開水箱護蓋，再用清水將水箱裝至 1/3 滿。

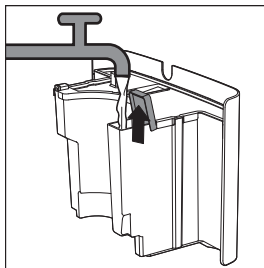

- 4 在水箱中的水加入一點溫和的清潔劑。
- 5 在水龍頭下沖洗水箱，再用柔軟的乾布清潔內部。

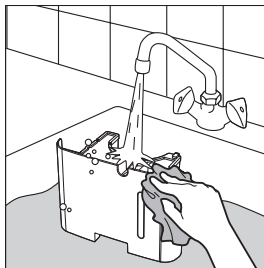

- 6 用清潔的布將水箱的外部擦乾。

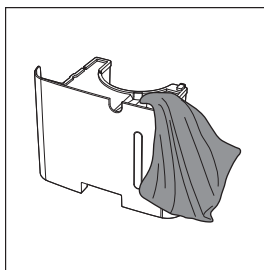

- 7 將水箱放回抽濕機。

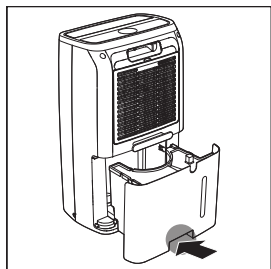

清潔後蓋

有需要時清潔後蓋可保持乾淨。

注意

- 後蓋可以清洗或以吸塵機清潔。

- 1 關閉抽濕機，並將其從電源插座拔出。
- 2 拉起後蓋，從抽濕機卸下。

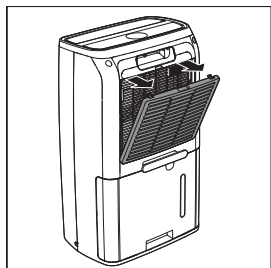

- 3 如果後蓋十分骯髒，可用軟刷將塵埃刷走。在水龍頭下沖洗後蓋。

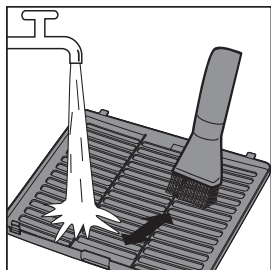

- 4 先徹底風乾後蓋，再裝回抽濕機內。
- 5 將後蓋裝回產品上。

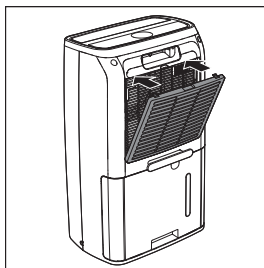

- 6 將抽濕機的插頭插入牆身插座。
- 7 清潔後蓋後，必須徹底洗淨雙手。

7 存放

- 1 關閉抽濕機，並將其從牆身插座拔出。
- 2 清潔抽濕機、清空水箱及清洗後蓋（請參閱「清潔」章節）。
- 3 必須讓所有部件乾透方可儲存。
- 4 將抽濕機置於乾爽的位置。

8 疑難排解

本章節總結一些您在抽濕機上最常見的問題。如以下資訊無法解決問題，請瀏覽 www.philips.com/support 或向所在國家/地區的客戶服務中心求助。

問題	可行解決方案
即使產品已經插入電源插座及開啟，但依然無法運作。	<ul style="list-style-type: none">• 定時功能設至特定時段。重設或關閉定時功能。• 嘗試其他電源插座或檢查牆身開關。• 確保已清空水箱並妥善放入抽濕機內。
水箱沒有水，但  指示燈仍然亮著。	<ul style="list-style-type: none">• 從抽濕機取出水箱，然後再放回至抽濕機內。
室內濕度並沒有降低，或抽濕效果不顯著。	<ul style="list-style-type: none">• 確保進氣口及送風口沒有受到阻塞。• 房內濕度低於抽濕機所設的濕度。選擇較低的濕度。• 確保沒有打開外門或窗戶。• 室內現時溫度過低。等待溫度回升後再試一次。
抽濕機漏水。	<ul style="list-style-type: none">• 確保抽濕機處於良好的運作狀態，而水箱沒有裂開。
抽濕機沒有集水。	<ul style="list-style-type: none">• 濕度低。當濕度增加時，抽濕機會自動繼續運作。• 溫度低。等待溫度回升。
排氣口排出的氣流比以前明顯減弱。	<ul style="list-style-type: none">• 後蓋髒了。清潔後蓋（請參閱「清潔」章節）。
抽濕機發出難聞氣味。	<ul style="list-style-type: none">• 頭幾次使用抽濕機時，抽濕機可能會發出一點塑膠氣味，此為正常。• 如抽濕機產生燒焦的氣味，請關閉電源，並將插頭從電源插座拔出。請聯絡您所在國家/地區的客戶服務中心求助。
抽濕機運作嘈吵。	<ul style="list-style-type: none">• 如果抽濕機太吵，可調低風扇速度。在夜晚於睡房內使用本產品時，請調低風扇速度。• 確保抽濕機放在平穩的表面上。
螢幕上顯示「E3」、「E4」或「E5」錯誤代碼。	<ul style="list-style-type: none">• 抽濕機故障。請聯絡您所在國家/地區的客戶服務中心。

9 保固與支援

Versuni 為這款產品提供購買後兩年保養。此保養不適用於因不正確使用或維護不良而造成的損壞。我們的保養不會影響您作為消費者的法律權利。有關啟動保養的詳情，請瀏覽我們的網站：www.philips.com/support。

訂購零件或配件

如果您需要更換零件或想訂購額外配件，請洽 Philips 經銷商或瀏覽 www.philips.com/support。

如果您索取有關零件時遇上問題，請聯絡您的國家/地區 Philips 客戶服務中心。

10 注意

電磁場 (EMF)

這款產品符合有關電磁場暴露的適用安全標準及條例。

回收

請勿在本產品使用壽命結束後當作一般家庭垃圾廢棄，應交給官方回收站或循環再用。這樣做有助保護環境。

請遵守您的國家/地區回收電器和電子產品的法則。正確處理有助避免對環境和人體造成負面影響。







PHILIPS and the Philips Shield Emblem are registered trademarks of Koninklijke Philips N.V. and are used under license.

This product has been manufactured by and is sold under the responsibility of Versuni Holding B.V., and Versuni Holding B.V. is the warrantor in relation to this product.

2023 © Versuni Holding B.V.

3000.103.4251.1 (20/04/2023)

