

Register your product and get support at
www.saeco.com/welcome

02

English

XSMALL

Type HD8642 / HD8643

USER MANUAL



EN

02

PLEASE READ THIS USER MANUAL CAREFULLY BEFORE USING THE MACHINE.

CE

 **Saeco**

IMPORTANT SAFEGUARDS

When using electrical appliances, basic safety precautions should always be followed, including the following:

1. Read all instructions.
2. Do not touch hot surfaces. Use handles or knobs.
3. To protect against fire, electric shock and injury to persons do not immerse cord, plugs, or appliance in water or other liquid.
4. Close supervision is necessary when the appliance is used by or near children.
5. Unplug from outlet when not in use and before cleaning. Allow to cool before putting on or taking off parts, and before cleaning the appliance.
6. Do not operate any appliance with a damaged cord or plug or after the appliance malfunctions, or has been damaged in any manner. Return appliance to the nearest authorized service facility for examination, repair or adjustment.
7. The use of accessory attachments not recommended by the appliance manufacturer may result in fire, electric shock or injury to persons.
8. Do not use outdoors.
9. Do not let cord hang over edge of table or counter, or touch hot surfaces.
10. Do not place on or near a hot gas or electric burner, or in a heated oven.
11. Always attach plug to appliance first, then plug cord into wall outlet. To disconnect, turn any control to "off", then remove plug from wall outlet.
12. Do not use appliance for other than intended use.
13. Save these instructions.

SAVE THESE INSTRUCTIONS

CAUTION

This appliance is for household use only. Any servicing, other than cleaning and user maintenance, should be performed by an authorized service center. Do not immerse machine in water. To reduce the risk of fire or electric shock, do not disassemble the machine. There are no parts inside the machine serviceable by the user. Repair should be done by authorized service personnel only.

1. Check voltage to be sure that the voltage indicated on the nameplate corresponds with your voltage.
2. Never use warm or hot water to fill the water tank. Use cold water only.
3. Keep your hands and the cord away from hot parts of the appliance during operation.
4. Never clean with scrubbing powders or harsh cleaners. Simply use a soft cloth dampened with water.
5. For optimal taste of your coffee, use purified or bottled water. Periodic descaling is still recommended every 2-3 months.
6. Do not use caramelized or flavored coffee beans.

INSTRUCTIONS FOR THE POWER SUPPLY CORD

- A. A short power-supply cord (or detachable power-supply cord) is to be provided to reduce risks resulting from becoming entangled in or tripping over a longer cord.
- B. Longer detachable power-supply cords or extension cords are available and may be used if care is exercised in their use.
- C. If a long detachable power-supply cord or extension cord is used,
 1. The marked electrical rating of the detachable power-supply cord or extension cord should be at least as great as the electrical rating of the appliance
 2. If the appliance is of the grounded type, the extension cord should be a grounding-type 3-wire cord, and
 3. The longer cord should be arranged so that it will not drape over the counter top or table top where it can be pulled on by children or tripped over.

Congratulations on your purchase of a Saeco Xsmall fully automatic espresso machine!

To fully benefit from the support that Philips Saeco offers, please register your product at www.saeco.com/welcome. The machine is suitable for preparing espresso coffee using whole coffee beans.

In this user manual you will find all the information you need to install, use, clean and descale your machine.

CONTENTS

IMPORTANT.....	4
Safety Instructions.....	4
Warnings.....	4
Cautions.....	6
Compliance with Standards.....	7
INSTALLATION.....	8
Product Overview.....	8
General Description.....	9
PREPARING FOR USE.....	10
Machine Packaging.....	10
Preparing for Use.....	10
USING THE MACHINE FOR THE FIRST TIME.....	12
Circuit Priming.....	12
Automatic Rinse/Self-Cleaning Cycle.....	13
"INTENZA+" Water Filter Installation.....	15
ADJUSTMENTS.....	16
Saeco Adapting System.....	16
Adjusting the Ceramic Coffee Grinder.....	17
Adjusting the Coffee Length.....	19
BREWING COFFEE.....	20
CLEANING AND MAINTENANCE.....	21
Daily Cleaning of the Machine.....	21
Daily Cleaning of the Water Tank.....	22
Weekly Cleaning of the Brew Group and of the Coffee Outlet Duct.....	22
Monthly Lubrication of the Brew Group.....	25
DESCALING.....	26
Preparation.....	26
Descaling.....	27
Rinsing.....	28
INTERRUPTION OF THE DESCALING CYCLE.....	30
UNDERSTANDING THE DIFFERENT LIGHTS.....	32
Control Panel.....	32
TROUBLESHOOTING.....	35
ENERGY SAVING.....	37
Stand-by.....	37
Disposal.....	37
TECHNICAL SPECIFICATIONS.....	38
WARRANTY AND SERVICE.....	38
Warranty.....	38
Service.....	38
ORDERING MAINTENANCE PRODUCTS.....	39

IMPORTANT

Safety Instructions

This machine is equipped with safety devices. Nevertheless, read and follow the safety instructions carefully and only use the machine properly as described in these instructions to avoid accidental injury or damage due to improper use of the machine. Keep this user manual for future reference.



The term **WARNING** and this icon warn against possible severe injuries, danger to life and/or damage to the machine.



The term **CAUTION** and this icon warn against slight injuries and/or damage to the machine.

Warnings

- Connect the machine to a wall socket with a voltage matching the technical specifications of the machine.
- Connect the machine to a earthed wall socket.
- Do not let the power cord hang over the edge of a table or counter, or touch hot surfaces.
- Never immerse the machine, the mains plug or power cord in water: Danger of electrical shock!
- Do not pour liquids on the power cord connector.
- Do not touch hot surfaces. Use handles and knobs.
- Remove the mains plug from the wall socket:
 - if a malfunction occurs;
 - If the machine will not be used for a long time;
 - before cleaning the machine.

Pull on the mains plug, not on the power cord. Do not touch the mains plug with wet hands.

- Do not use the machine if the mains plug, the power cord or the machine itself is damaged.
- Do not make any modifications to the machine or its power cord. Only have repairs carried out by a service centre authorised by Philips to avoid any hazard.
- The machine should not be used by children younger than 8 years old.
- The machine can be used by children of 8 years and upwards if they have previously been instructed on the correct use of the machine and made aware of the associated dangers or if they are supervised by an adult.
- Cleaning and maintenance should not be carried out by children unless they are more than 8 years old and supervised by an adult.
- Keep the machine and its power cord out of reach of children under 8 years old.
- The machine may be used by persons with reduced physical, sensory or mental capabilities or lacking sufficient experience and/or skills if they have previously been instructed on the correct use of the machine and made aware of the associated dangers or if they are supervised by an adult.
- Children should be supervised to ensure that they do not play with the machine.
- Never insert fingers or other objects into the coffee grinder.

Cautions

- The machine is for household use only. It is not intended for use in environments such as canteens, staff kitchens of shops, offices, farms or other work environments.
- Always put the machine on a flat and stable surface.
- Do not place the machine on hot surfaces, directly next to a hot oven, heater units or similar sources of heat.
- Only put roasted coffee beans into the coffee bean hopper. If ground coffee, instant coffee, raw coffee beans or any other substance is put in the coffee bean hopper, it may damage the machine.
- Let the machine cool down before inserting or removing any parts.
- Never use warm or hot water to fill the water tank. Use only cold non-sparkling drinking water.
- Never clean with scrubbing powders or harsh cleaners. Simply use a soft cloth dampened with water.
- Descale your machine regularly. The machine indicates when descaling is needed. Not doing this will make your appliance stop working properly. In this case repair is not covered under your warranty!
- Do not keep the machine at temperature below 0 °C. Residue water in the heating system may freeze and cause damage.
- Do not leave water in the water tank if the machine is not used over a long period of time. The water can get contaminated. Use fresh water every time you use the machine.

Compliance with Standards

The machine complies with art.13 of the Italian Legislative Decree dated 25 July 2005, no. 151 "Implementation of the Directives 2005/95/EC, 2002/96/EC and 2003/108/EC on the restriction of the use of certain hazardous substances in electrical and electronic equipment, as well as waste disposal".

This machine complies with EU Directive 2002/96/EC.

This Philips appliance complies with all the applicable standards and regulations relating to the exposure to electromagnetic fields.

INSTALLATION

Product Overview

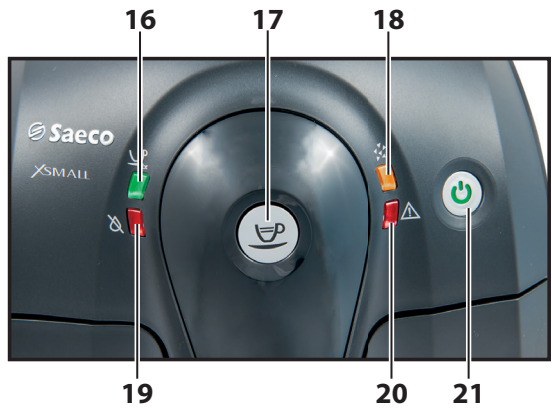
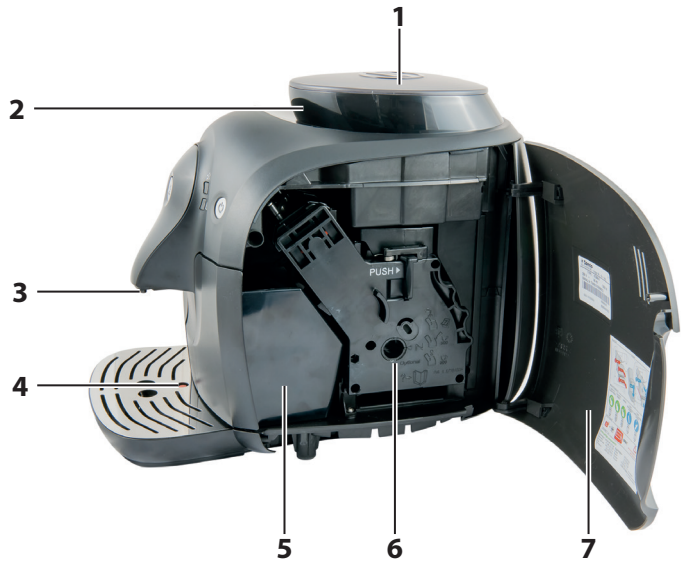

General Description

1. Coffee bean hopper lid
2. Coffee bean hopper
3. Coffee dispensing spout
4. Full drip tray indicator
5. Coffee grounds drawer
6. Brew group
7. Service door
8. Control panel
9. Grill
10. Drip tray
11. Water tank
12. Grinder adjustment knob
13. Ceramic coffee grinder
14. Power cord
15. Grinder adjustment key
16. "Double coffee" light
17. Coffee button
18. Descaling light
19. No water light
20. Warning light
21. ON/OFF button with machine ready light

PREPARING FOR USE

Machine Packaging

The original packaging has been designed and constructed to protect the machine during transport. We recommend keeping the packaging material for possible future transport.

Preparing for Use

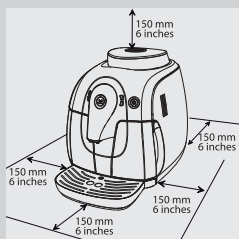

1 Remove the coffee bean hopper lid and the drip tray with grill from the packaging.

2 Remove the machine from the packaging.

3 For best use, it is recommended to:

- Choose a safe, level surface, where there will be no danger of overturning the machine or being injured.
- Choose a location that is sufficiently well-lit, clean and near an easily reachable socket.
- Allow for a minimum distance from the sides of the machine as shown in the illustration.

4 Insert the drip tray with grill into the machine. Make sure it is fully inserted.

Note:

The drip tray collects the water that comes out of the dispensing spout during each rinse/self-cleaning cycle, as well as coffee that might be spilled during coffee preparation. Empty and wash the drip tray daily and each time the full drip tray indicator is raised.

Caution:

NEVER remove the drip tray when the machine has just been turned on. Wait a couple of minutes for the machine to carry out a rinse/self-cleaning cycle.



5 Remove the water tank.



6 Rinse the water tank with fresh water.

7 Fill the water tank with fresh water up to the MAX level and reinsert it into the machine. Make sure it is fully inserted.



Caution:

Never fill the water tank with warm, hot, sparkling water or any other liquid, as this may cause damage to the water tank and the machine.



8 Slowly pour the coffee beans into the coffee bean hopper.



Caution:

Only coffee beans must be put into the coffee bean hopper. If ground coffee, instant coffee, raw coffee beans or any other substance is put in the coffee bean hopper, it may damage the machine.



9 Put the lid on the coffee bean hopper.





10 Insert the plug into the socket located on the back of the machine.



- 11** Insert the plug at the other end of the power cord into a wall socket with suitable power voltage.



- 12** Press the “” ON/OFF button to turn the machine on; the “” light will begin to flash quickly, indicating that the circuit has to be primed.

USING THE MACHINE FOR THE FIRST TIME

When using the machine for the first time, the following activities need to happen:

- 1) You need to prime the circuit.
- 2) The machine will perform an automatic rinse/self-cleaning cycle.

Circuit Priming

During this process, fresh water flows through the internal circuit of the machine and the machine warms up. This takes a few seconds.



- 1** Place a container (1L) under the coffee dispensing spout.

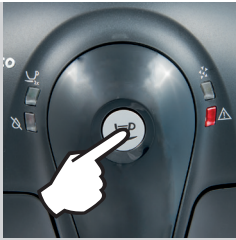

- 2 Press the "☕" button. The machine dispenses water for a few seconds. The "⏻" light flashes slowly and the "⚠️" light turns off.



- 3 When water dispensing stops, the "⏻" light flashes slowly. The machine is warming up.

Automatic Rinse/Self-Cleaning Cycle

When warm-up has been completed, the machine automatically performs a rinse/self-cleaning cycle of the internal circuits with fresh water. This takes less than a minute.



- 1 Place the container under the coffee dispensing spout to catch the small amount of water which will be dispensed.



- 2 The "⏻" light flashes slowly.
3 Wait for water dispensing to stop.



Note:

You can stop dispensing by pressing the "☕" button.



4 The "⏻" light shines steadily. The machine is ready to brew coffee.

 **Notes:**

The automatic rinse/self-cleaning cycle is initiated when the machine has been in stand-by mode, or turned off, for more than 15 minutes. When you have not used the machine for 2 or more weeks you also have to perform the manual rinsing cycle. At the end of the cycle, it is possible to brew a coffee.

“INTENZA+” Water Filter Installation

We recommend you to install the “INTENZA+” water filter as this prevents limescale build-up in your machine and preserves a more intense aroma of your coffee.



The “INTENZA+” water filter can be purchased separately. For further details, please refer to the maintenance products page in this manual. Water is a crucial part of every coffee, so it is very important to always have it professionally filtered. Using the “INTENZA+” water filter will prevent mineral deposits from building up and improve your water quality.

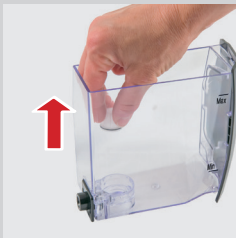

- 1 Remove the small white filter from the water tank and store it in a dry place.



- 2 Remove the “INTENZA+” water filter from its packaging, immerse it vertically (with the opening positioned upwards) in cold water and gently press the sides so as to let the air bubbles out.



- 3 Set the “INTENZA+” water filter according to the hardness of the water used:
 - A = Soft water
 - B = Hard water (standard)
 - C = Very hard water



4 Put the "INTENZA +" water filter into the empty water tank. Press it down until it cannot move any further.

5 Fill the water tank with fresh water and reinsert it into the machine.

6 Brew a few coffees (see the "Brewing coffee" section).

7 Remove the tank, fill it with fresh water up to the MAX level and place it back into the machine.



8 When the operations described above have been completed, the "⏻" light shines steadily. Machine is ready to brew coffee.



Note:

We recommend replacing the "INTENZA +" water filter every 2 months.

ADJUSTMENTS

The machine allows for certain adjustments so that you can brew the best tasting coffee possible.

Saeco Adapting System

Coffee is a natural product and its characteristics may change according to its origin, blend and roast. The machine is equipped with a self-adjusting system that allows the use of all types of coffee beans available on the market except for raw, caramelized and flavoured coffee beans. The machine automatically adjusts itself after brewing a certain number of cups of coffee to optimise the extraction.

Adjusting the Ceramic Coffee Grinder

Ceramic coffee grinders always guarantee accurate and perfect grinding and coarseness for every coffee speciality. This provides full aroma preservation, delivering a truly Italian taste in every cup.



Warning:

Do not insert fingers or other objects. Only adjust the ceramic coffee grinder using the grinder adjustment key. The ceramic coffee grinder contains moving parts that may be dangerous.

You can adjust the ceramic grinders to set the coffee grinding to your personal taste.



Warning:

You can only adjust the coffee grinder settings when the machine is grinding coffee beans.



- 1 Remove the coffee bean hopper lid.

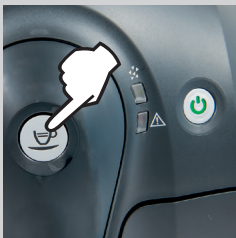

- 2 Make sure that the "⏻" green light shines steadily, and that the water tank and the coffee bean hopper are full. Press the "☕" coffee button; the coffee grinder starts grinding.



Note:

Use the coffee grinder adjustment key provided with the machine. You will taste the difference after brewing 2-3 cups of coffee. If coffee is watery or is brewed slowly, change the coffee grinder settings.

- 3 While the coffee grinder is operating, press and turn the grinder adjustment knob inside the coffee bean hopper one notch at a time.



Warning:

Do not turn the coffee grinder more than one notch at the time to prevent damage.



- 4 The reference marks inside the coffee bean hopper indicate the grind setting. There are 5 different grind settings to choose, from position 1 (●) for coarse grind - lighter taste to position 2 (●) for fine grind - stronger taste.



- 5 When adjusting has been completed, put the lid back on the coffee bean hopper.

Adjusting the Coffee Length

The machine allows you to adjust the amount of brewed coffee according to your taste and the size of your cups.

Each time the “☕” coffee button is pressed and released, the machine brews a pre-set amount of coffee.



- 1 Place a cup under the coffee dispensing spout.



- 2 Press and hold the “☕” button for a few seconds; until the “☕_{2x}” and “⏻” lights flash slowly.



- 3 Wait until the desired quantity is reached, then press the “☕” button to stop brewing.

Now the “☕” button is programmed; each time it is pressed, the machine will brew the same amount of coffee that was just programmed.

BREWING COFFEE

Before brewing coffee, make sure that the “” green light shines steadily on and that the water tank and coffee bean hopper are full.



- 1** Place 1 or 2 cups under the coffee dispensing spout.
- 2** Press the “” brew button.
- 3** To dispense 1 cup of coffee, press the button once. To dispense 2 cups of coffee, press the button twice consecutively.

In this operating mode, the machine automatically grinds and doses the correct amount of coffee. Brewing two coffees requires two grinding and brewing cycles, automatically carried out by the machine; during this time, the “” light is shining steadily.

- 4** After the prebrewing cycle, coffee begins to pour out of the coffee dispensing spout.
- 5** Brewing stops automatically when the preset level is reached. You can press the “” button to stop brewing early.

CLEANING AND MAINTENANCE

Daily Cleaning of the Machine



Caution:

Timely cleaning and maintenance of your machine is very important as it prolongs the life of your machine. Your machine is continuously exposed to moisture, coffee and limescale!

The activities you need to perform and their frequency are described in detail in this chapter. Not doing this will ultimately make your machine stop working properly. This repair is NOT covered by warranty!



Note:

- Use a soft, dampened cloth to clean the machine.
- Do not immerse the machine in water.
- Do not wash any of its parts in the dishwasher.
- Do not use alcohol, solvents, and/or abrasive objects to clean the machine.
- Do not dry the machine and/or its parts using a microwave and/or standard oven.



- 1 Empty and clean the coffee grounds drawer daily with the machine turned on.

Other maintenance operations can only be carried out when the machine is turned off and unplugged.



- 2 Empty and clean the drip tray. Perform this operation also when the full drip tray indicator is raised.

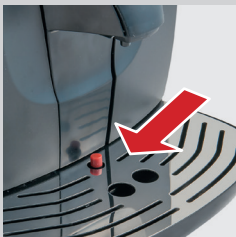

Daily Cleaning of the Water Tank



- 1 Remove the small white filter or the "INTENZA+" water filter (if installed) from the water tank and wash it with fresh water.
- 2 Put the small white filter back or the "INTENZA+" water filter (if installed) in its housing by gently pressing and turning it at the same time.
- 3 Fill the water tank with fresh water.

Weekly Cleaning of the Brew Group and of the Coffee Outlet Duct

The brew group should be cleaned every time the coffee bean hopper is filled or at least once a week.



- 1 Turn off the machine by pressing the "ON/OFF" button and unplug the power cord.



- 2 Remove the coffee grounds drawer. Open the service door.

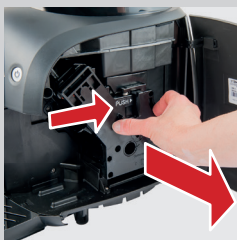

- 3 To remove the brew group, press the «PUSH» button and pull it by the handle. Pull it out horizontally without turning it by pulling it by the handle.



- 4** Clean the coffee outlet duct thoroughly with a spoon handle or with another round-tipped kitchen utensil.



- 5** Thoroughly wash the brew group with fresh, lukewarm water and carefully clean the upper filter.



Caution:
do not use detergent or soap to clean the brew group.

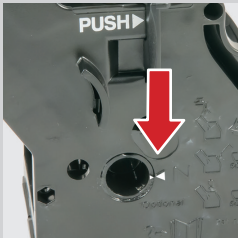

- 6** Let the brew group air-dry thoroughly.

- 7** Thoroughly clean the inside of the machine using a soft, dampened cloth.

- 8** Make sure the brew group is in the off position; the two reference signs must match. If they do not match, proceed as described in step (9).

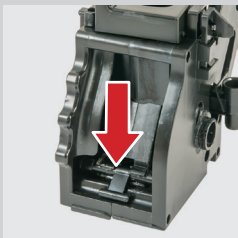

- 9** Gently pull down the lever on the back of the group until it is in contact with the brew group base and the two reference signs on the side of the brew group match.

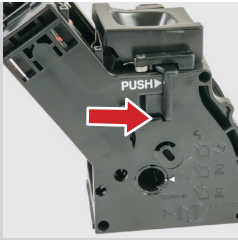

10 Press the "PUSH" button firmly.

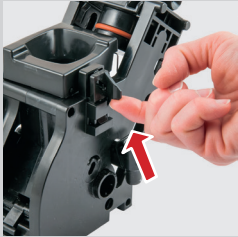

11 Make sure that the hook which locks the brew group is in the correct position. If it is still in the downward position push it upward until it locks correctly into place.



12 Insert the brew group in its seat again until it locks into place WITHOUT pressing the "PUSH" button.

13 Insert the coffee grounds drawer. Close the service door.

Monthly Lubrication of the Brew Group



Lubricate the brew group after approximately 500 cups of coffee or once a month. The grease to lubricate the brew group can be purchased separately. For further details, please refer to the maintenance products page in this manual.



Caution:

Before lubricating the brew group, clean it under fresh water and let it dry, as described in the "Brew Group Weekly Cleaning" section.

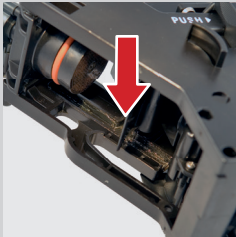

- 1 Apply the grease evenly on both side guides.

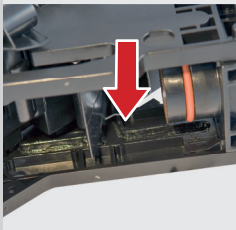

- 2 Also lubricate the shaft.

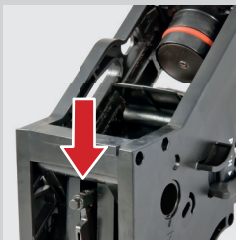

- 3 Insert the brew group in its seat until it locks into place. (see "Brew Group Weekly Cleaning" section).

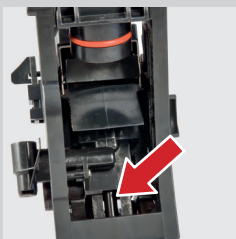

- 4 Insert the coffee grounds drawer and close the service door.

DESCALING



When the “” orange light turns on, you need to descale the machine.

Descaling time: 30 minutes

Not doing this will ultimately make your machine stop working properly. In this case, repair is NOT covered by warranty.



Warning:

Use the Saeco descaling solution only. Its formula has been designed to ensure better machine performance. The use of other products may damage the machine and leave residues in the water.



The Saeco descaling solution can be purchased separately. For further details, please refer to the maintenance products page in this manual.



Warning:

Never drink the descaling solution or any products dispensed until the cycle has been carried out to the end. Never use vinegar as a descaling solution.

Do not remove the brew group during the descaling cycle.

Preparation



1 Turn off the machine by pressing the ON/OFF “” button.



Note:

If you don't turn off machine, you'll be making a coffee instead of activating the descaling cycle!



- 2 Before beginning the descaling cycle, empty the drip tray and reinsert it, remove the "Intenza+" water filter if installed.

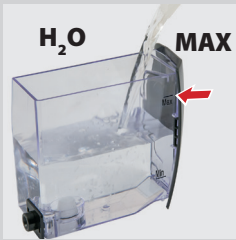

- 3 Remove and empty the water tank. Pour in the entire content of the Saeco descaling solution. Fill the water tank with fresh water up to the MAX level. Put the water tank back into the machine.



- 4 Place a large container under the coffee dispensing spout.

Descaling



- 5 Press the "☕" button for about 5 seconds.



- 6 The "☼" orange light starts flashing slowly and will continue to do so during the whole descaling cycle. The machine dispenses the descaling solution several times after one-minute intervals from the coffee dispensing spout until the water tank is completely empty. This procedure takes approx. 20 minutes.

**Note:**

if you wish to interrupt dispensing the descaling solution (for example to empty the container), press the "☕" button. Press the "☕" button again to resume dispensing.



- 7 When the "☼" red light turns on, remove and empty the container placed under the coffee dispensing spout and the drip tray, then place them back in position.

Rinsing

- 8 Remove the water tank, rinse it and fill it up with fresh water up to the MAX level. If the water tank is not filled up to MAX level, the machine might require more rinse cycles. Put the water tank back into the machine.



- 9 The "☼" orange light flashes double during the whole rinse cycle. The machine starts dispensing water through the coffee dispensing spout.



Note:

if you wish to interrupt water dispensing (for example to empty the container), press the "☕" button. Press the "☕" button again to resume dispensing.



10 When the rinse cycle has been completed, the "⚡" orange light turns off and the "⏻" green light flashes. The machine warms up and performs the automatic rinse cycle.



Note:

If the "⚡" red light turns on and the "⚡" orange light is still flashing, the water tank has not been filled to the MAX level for the rinse cycle. Fill the water tank with fresh water. The rinse cycle will resume from point 9.



11 When the "⏻" green light shines steadily, remove the drip tray, rinse it and place it back.



12 Remove and rinse the water tank. Reinstall the "INTENZA+" water filter (if any). Fill the water tank with fresh water up to the MAX level. Put the water tank back into the machine.



13 The machine is ready to brew coffee.

INTERRUPTION OF THE DESCALING CYCLE

Once you have started the descaling cycle, you must complete it till the very end without turning off the machine.
In case you get stuck during the descaling procedure, you can exit by unplugging the power cord. If that happens follow the steps below.



- 1 Empty the drip tray.

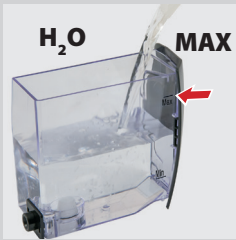

- 2 Empty and rinse carefully the water tank, then fill it with fresh water up to the MAX level.



- 3 Turn on the machine. The machine will start the automatic rinse cycle.



- 4 Place a container under the dispensing spout. Press the "☕" button and dispense 300 ml of coffee.



5 Empty the container. The machine is ready for use.



Note:

If the “” orange led does not turn off you still have to descale your machine at your earliest convenience.

UNDERSTANDING THE DIFFERENT LIGHTS

Control Panel



Light Signals

Causes

Solutions



Steady on

The machine has reached the right temperature and is ready to brew coffee.



Flashing slowly

The machine is warming up to dispense coffee.
The machine is performing the rinse/self-cleaning phase.
The machine is dispensing.

The machine ends the rinse/self-cleaning cycle automatically. You can interrupt the rinse/self-cleaning cycle by pressing the "☕" button.



☕ and ⏻ steady on

The machine needs descaling!















Not descaling your machine will ultimately make it stop working properly.
This repair is not covered by your warranty.









☕ flashing slowly

The machine is in the descaling mode.

Descaling first phase with descaling solution.
Complete the descaling procedure.

Light Signals	Causes	Solutions
 <p> flashing twice</p>	<p>The machine is in the descaling mode.</p>	<p>Descaling second phase with fresh water. Complete the descaling procedure.</p>
 <p> flashing slowly and  light steady on.</p>	<p>The machine is in the descaling mode.</p>	<p>Rinse the water tank and fill it up to the MAX level. Complete the descaling procedure.</p>
 <p> and  lights flashing slowly</p>	<p>The machine is programming the amount of coffee to be brewed.</p>	<p>Press the button as soon as the desired amount of coffee is reached.</p>
 <p> Steady on and  light flashing slowly</p>	<p>The machine is brewing a double coffee.</p>	
 <p>Steady on</p>	<p>Low water level.</p>	<p>Fill the water tank with fresh water. After putting the filled water tank back, the indicator light turns off.</p>
 <p> and  steady on</p>	<p>The coffee bean hopper is empty.</p>	<p>Fill the coffee bean hopper with coffee beans and start the procedure again.</p>

Light Signals	Causes	Solutions
 <p data-bbox="220 425 327 455">⚠ Steady on</p>	<p data-bbox="409 271 628 296">The coffee grounds drawer is full.</p>	<p data-bbox="700 266 1138 366">With the machine turned on, empty the coffee grounds drawer. If the coffee grounds drawer is emptied when the machine is off, the coffee cycle counter is not reset. Wait until the  light starts flashing before putting back the coffee grounds drawer.</p>
 <p data-bbox="198 626 349 656">⚠ Flashing quickly</p>	<p data-bbox="409 467 584 492">The water circuit is empty.</p>	<p data-bbox="700 467 1138 513">Fill the water tank with fresh water and prime the water circuit as described in the "Using the Machine for the First Time" section.</p>
 <p data-bbox="198 827 349 857">⚠ Flashing slowly</p>	<p data-bbox="409 668 683 744">Brew group is not inserted. The coffee grounds drawer is not inserted. Service door is open.</p>	<p data-bbox="700 668 1138 725">Make sure that all components have been correctly inserted and closed. The  flashing light will now turn off.</p>
 <p data-bbox="172 1028 370 1058">⚠ and ⏻ flashing slowly</p>	<p data-bbox="409 869 667 894">A fault has occurred in the brew group.</p>	<p data-bbox="700 869 1048 894">Try again to brew another espresso or another coffee.</p>
 <p data-bbox="198 1236 345 1284">All lights are flashing simultaneously</p>	<p data-bbox="409 1070 593 1095">The machine is out of order.</p>	<p data-bbox="700 1070 1053 1118">Turn off the machine. Turn it back on after 30 seconds. Try this 2 or 3 times.</p> <p data-bbox="700 1123 1117 1148">If the machine does NOT start, contact the Philips Saeco hotline.</p>

TROUBLESHOOTING

This chapter summarizes the most common problems you could encounter with your machine. If you are unable to solve the problem with the information below, visit www.saeco.com/support for a list of frequently asked questions or contact the Philips Saeco hotline in your country. The contact details can be found in the warranty booklet packed separately or on www.saeco.com/support.

Problem	Possible Cause	Solution
The machine does not turn on.	The machine is not connected to the power source.	Connect the machine to the power source.
Coffee is not hot enough.	The cups are cold.	Preheat the cups with hot water.
Coffee does not have enough crema (see note).	The coffee blend is unsuitable, the coffee is not freshly roasted or the grind is too coarse.	Change coffee blend or adjust the ceramic coffee grinder as explained in the "Adjusting the Ceramic Coffee Grinder" section.
The machine needs too much time to warm up.	The machine water circuit is obstructed by limescale build-up.	Descale the machine.
The brew group cannot be removed.	The brew group is out of place.	Turn on the machine. Close the service door. The brew group automatically returns to the correct position.
	The coffee grounds drawer is inserted.	Remove the coffee grounds drawer before removing the brew group.
The brew group cannot be inserted.	The brew group is not in the off position.	Make sure that the brew group is in the off position, as described in the "Weekly Cleaning of the Brew Group" chapter.
	The gearbox is not in the correct position.	Insert the drip tray and the coffee grounds drawer. Close the service door. Turn on the machine without inserting the brew group. The gearbox returns to the correct position. Turn off the machine and reinsert the brew group as described in the "Weekly Cleaning of the Brew Group" chapter
The descaling cycle cannot be finished.	Most probably you have used not enough water for rinsing.	Unplug the power cord and follow the instructions described in the sector "Interruption of the descaling cycle".

Problem	Possible Cause	Solution
The machine grinds the coffee beans but no coffee is brewed (see note).	The brew group is dirty.	Clean the brew group ("Brew Group Cleaning" section).
	This might occur when the machine is automatically adjusting the dose.	Brew a few cups of espresso coffee as described in the "Saeco Adapting System" section.
	The coffee dispensing spout is dirty.	Clean the coffee dispensing spout.
The coffee is too weak (see note).	This might occur when the machine is automatically adjusting the dose.	Brew a few cups of espresso coffee as described in the "Saeco Adapting System" section.
	The ceramic coffee grinder is set to a coarse grind.	Adjust the ceramic coffee grinder to a finer setting (see the "Adjusting the Ceramic Coffee Grinder" section).
Coffee is brewed slowly (see note).	The coffee grind is too fine.	Change coffee blend or adjust the grind setting as explained in the "Adjusting the Ceramic Coffee Grinder" section.
	The brew group is dirty.	Clean the brew group ("Brew Group Cleaning" section).
The drip tray gets filled although no water is drained.	Water is drained automatically by the machine into the drip tray to manage the rinsing of the circuits.	This is a standard operating procedure.

**Note:**

These problems can be considered normal if the coffee blend has been changed or if the machine has just been installed. In this case, wait until the machine performs a self-adjusting operation as described in the "Saeco Adapting System" section.

ENERGY SAVING

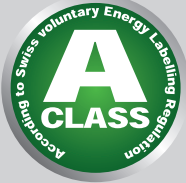

Stand-by

The machine is designed for energy saving- proven by the Class A energy label.

After 30 minutes of inactivity, the machine turns off automatically.

Disposal



Do not throw away the machine with the normal household waste at the end of its life, but hand it in at an official collection point for recycling. By doing this, you help to preserve the environment.

Packaging materials can be recycled.

- Machine: unplug the machine and cut the power cord.
- Deliver the appliance and power cord to a service centre or public waste disposal facility.

This product complies with EU Directive 2002/96/EC.

The symbol on the product or on the packaging indicates that this product may not be treated as household waste, instead it shall be handed over to the applicable collection point for the recycling of electrical and electronic equipment.

By ensuring this product is disposed of correctly, you will help prevent potential negative consequences for the environment and human health, which could otherwise be caused by inappropriate waste handling of this product. For more detailed information about recycling this product, please contact your local city office, your household waste disposal service or the shop where you purchased the product.

TECHNICAL SPECIFICATIONS

The manufacturer reserves the right to make changes to the technical specifications of the product.	
Nominal Voltage - Power Rating - Power Supply	See data plate on the inside of the service door
Housing material	ABS - Thermoplastic
Size (w x h x d)	295 x 325 x 420 mm - 11.5" x 13" x 16.5"
Weight	6.9 kg - 15 lbs
Power cord length	800 - 1200 mm / 31.5" - 47"
Control panel	Front panel
Cup sizes	Up to 95mm
Water tank	1.0 litres – 33 oz. / removable
Coffee bean hopper capacity	200 g / 7.0 oz.
Coffee grounds drawer capacity	8
Pump pressure	15 bar
Boiler	Stainless Steel
Safety devices	Thermal fuse

WARRANTY AND SERVICE

Warranty

For detailed information on your warranty and related conditions, please read the warranty booklet supplied separately.

Service

We want to ensure that you remain satisfied with your machine. If you have not already done so, please register your purchase at **www.saeco.com/welcome**. This will enable us to stay in contact with you and send you cleaning and descaling reminders.

For service or support, please visit the Philips website at **www.saeco.com/support** or contact the Philips Saeco hotline in your country. The contact details can be found in the warranty booklet packed separately or on **www.saeco.com/support**.

ORDERING MAINTENANCE PRODUCTS

For cleaning and descaling, use Saeco maintenance products only. You can purchase the products at the Philips online shop (if available in your country) at www.shop.philips.com/service, from your local dealer or authorised service centres.

If you have any difficulties obtaining maintenance products for your machine, please contact the Philips Saeco hotline in your country.

The contact details can be found in the warranty booklet supplied separately or on www.saeco.com/support.

Overview of maintenance products

- INTENZA+ WATER FILTER (CA6702)



- GREASE (HD5061)



- DESCALING SOLUTION (CA6700)



- MAINTENANCE KIT (CA 6706)



02

Rev.00 del 15-06-14

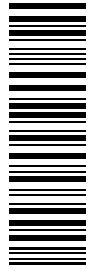

421946013341

EN

02

The manufacturer reserves the right to make changes without prior notice.



www.philips.com/saeco