



EN User manual ID Buku Petunjuk Pengguna

PHILIPS
PENANAK NASI
HD4515
Daya memasak: 400W
220V ~ 50-60Hz
Negara Pembuat: Cina
Dilimpur oleh:
PT Versuni HomeLife Indonesia
Gedung Cibis Nine, lantai 10, Jl. TB Simatupang No. 2,
RT 001/RW 005 Kelurahan Cilandak Timur, Kec. Pasar
Minggu, Kota Adm. Jakarta Selatan, - DKI Jakarta, 12560
- INDONESIA
Negara Pembuat: Cina
No. Reg.: IMKG.1236.07.2023

PHILIPS and the Philips Shield Emblem are registered trademarks of Koninklijke Philips N.V. and are used under license. This product has been manufactured by and is sold under the responsibility of Versuni Holding B.V. and Versuni Holding B.V. is the warrantor in relation to this product.
2023 © Versuni Holding B.V.

6608.000.0785.7 (11/07/2023)

English

1 Important

Read this user manual carefully before you use the Rice cooker and save it for future reference.

Danger

- The appliance must not be immersed.

Warning

- This appliance is not intended for use by persons (including children) with reduced physical sensory or mental capabilities, or lack of experience and knowledge, unless they have been given supervision or instruction concerning use of the appliance by a person responsible for their safety.
- Children should be supervised to ensure that they do not play with the appliance.
- This appliance should be positioned in a stable situation with the handles (if any) positioned to avoid spillage of the hot liquids.
- This appliance is intended to be used in household and similar applications such as:
 - Staff kitchen areas in shops, offices and other working environments;
 - Farm houses;
 - By clients in hotels, motels and other residential type environments;
 - Bed and breakfast type environments.

- If the power cord set is damaged, it must be replaced by a cord set available from the manufacturer.
- The appliance is not intended to be operated by means of an external timer or a separate remote-control system.
- Check if the voltage indicated on the appliance corresponds to the local power voltage before you connect it.
- Only connect the appliance to a grounded power outlet. Always make sure that the plug is inserted firmly into the power outlet.
- Do not use the appliance if the plug, the power cord, the inner pot, the sealing ring, or the main body is damaged.
- Make sure the heating element, the temperature sensor, and the outside of the inner pot are clean and dry before you put the plug in the power outlet.
- Do not plug in the appliance or press any of the buttons on the control panel with wet hands.
- WARNING: Make sure to avoid spillage on the power connector to avoid a potential hazard.
- WARNING: Always follow the instructions and use the appliance properly to avoid potential injury.

- According to the instructions prescribed in this user manual, use a soft damp cloth to clean the surfaces in contact with food and make sure to remove all the food residues stuck to the appliance.
- Don't place the power cord under the appliance when in use.
- When placing the steaming basket, avoid touching the side wall of the inner pot, otherwise it may cause deformation due to high temperature.
- CAUTION: Surface of the heating element is subject to residual heat after use.
- According to the installation prescribed in this user manual, use a soft damp cloth to clean the surfaces in contact with food and make sure to remove all the food residues stuck to the appliance.
- Never use any accessories or parts from other manufacturers or that Philips does not specifically recommend. If you use such accessories or parts, your guarantee becomes invalid.
- Do not expose the appliance to high temperatures, nor place it on a working or still hot stove or cooker.
- Do not expose the appliance to direct sunlight.
- Place the appliance on a stable, horizontal, and level surface.

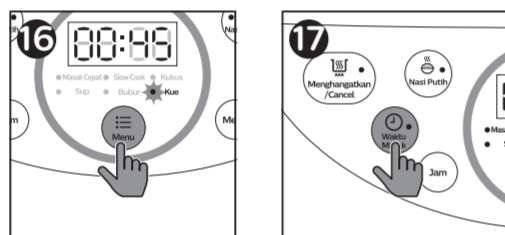
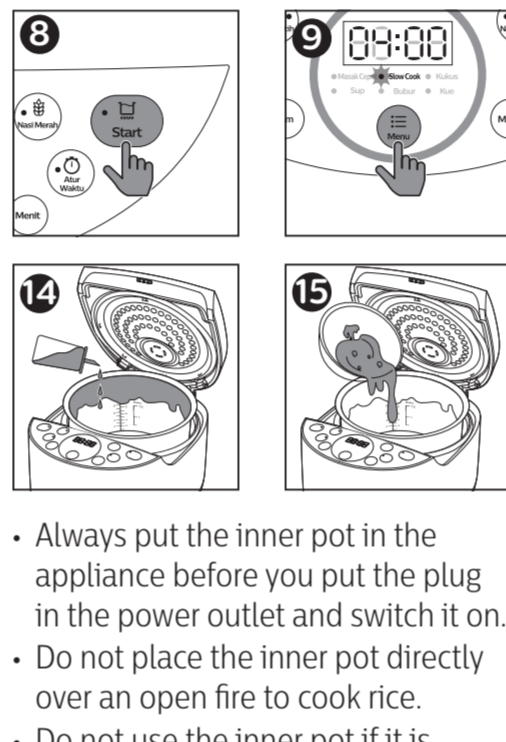
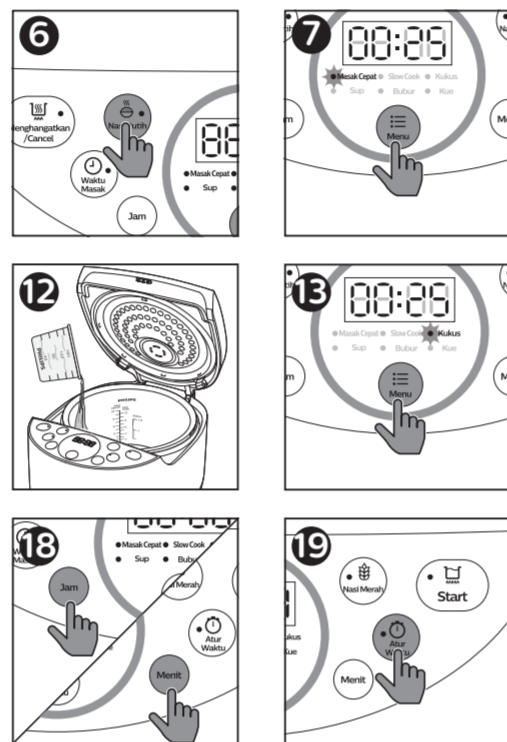
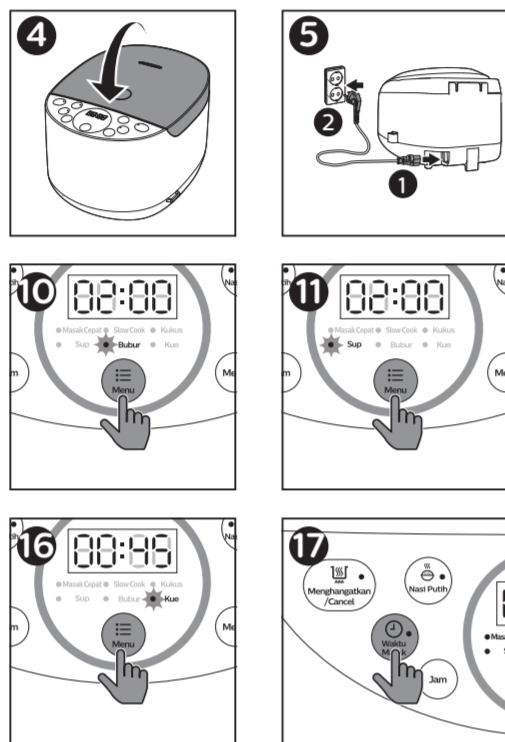
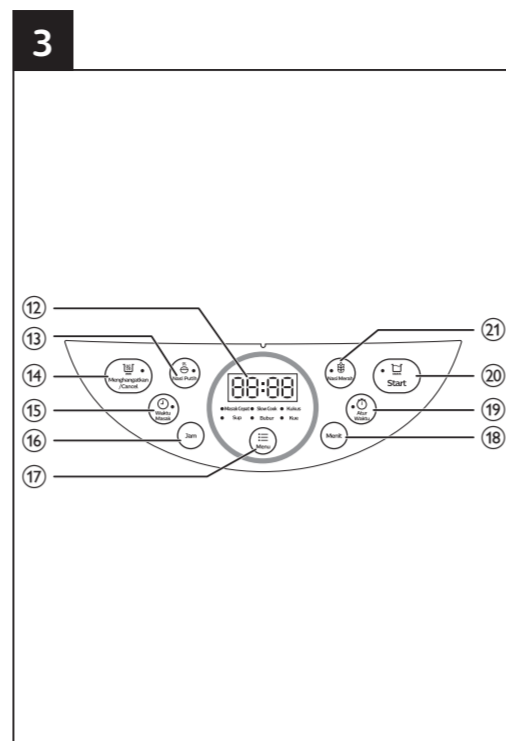
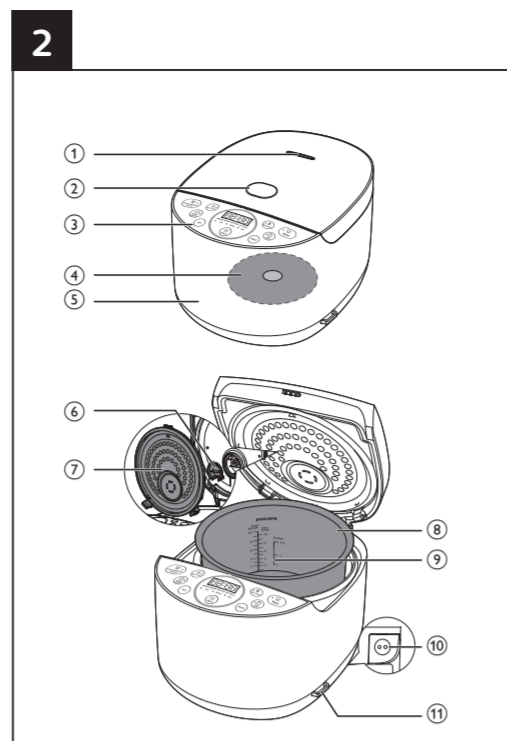
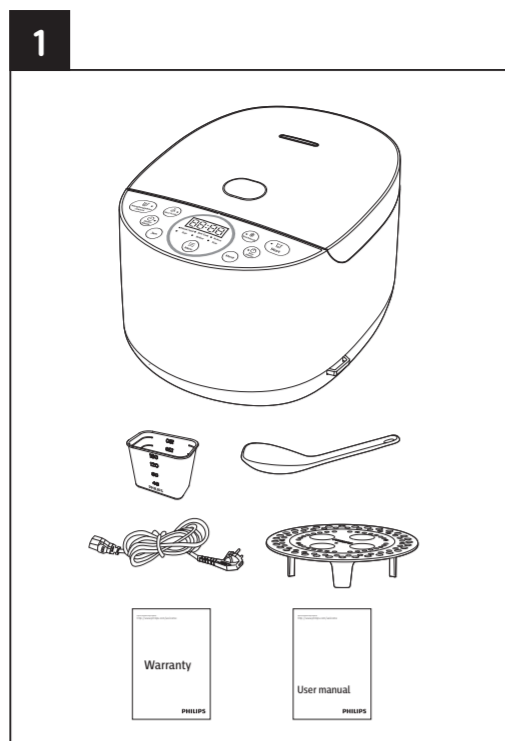

- Always clean the appliance after use. Do not clean the appliance in a dishwasher.
- Always unplug the appliance if not used for a longer period.
- If the appliance is used improperly or for professional or semiprofessional purposes, or if it is not used according to the instructions in this user manual, the guarantee becomes invalid and Philips refuses liability for any damage caused.

Electromagnetic fields (EMF)

This appliance complies with the applicable standards and regulations regarding exposure to electromagnetic fields.

2 Your Rice cooker

Congratulations on your purchase, and welcome to Philips! To fully benefit from the support that Philips offers, register your product at www.philips.com/welcome.

3 What's in the box (fig. 1)

Rice cooker main unit	Measuring cup
Rice and soup 2 in 1 spoon	Power cord
Steaming basket	User manual
Warranty card	

4 Overview (fig. 2)

① Steam vent	⑦ Detachable inner lid
② Lid release button	⑧ Inner pot
③ Control panel	⑨ Water level indications
④ Heating element	⑩ Power socket
⑤ Main body	⑪ Cooker base
⑥ Steam vent cap	

Controls overview (fig. 3)

⑫ Display screen	⑰ Menu button
⑬ White button	⑱ Minute button
⑭ Keep-warm/Cancel button	⑲ Preset time button
⑮ Cooking time button	⑳ Start button
⑯ Hour button	㉑ Brown rice button

5 Using the Rice cooker

Before first use

- Take out all the accessories from the inner pot. Remove the packaging material of the inner pot.
- Rinse first use, boil water and clean the Rice cooker.
- Clean the parts of the Rice cooker thoroughly before using it for the first time (see chapter "Cleaning and Maintenance").

Note

- Make sure all parts are completely dry before you start using the Rice cooker.

Cooking rice

Cooking function	Estimated cooking time	Time regulation	Preset time
White(Nasi Putih)	1 hour	/	1-24 hours
Brown (Nasi Merah)	2 hours	/	1-24 hours
Fast cook (Masak Cepat)	25 minutes	/	1-24 hours

You can cook rice using the White, Brown or fast cook function.

- Measure rice using the measuring cup provided.
- Rinse rice, and put the washed rice in the inner pot.
- Add water to the level indicated on the scale inside the inner pot that corresponds to the number of cups of rice used. Then smooth the rice surface.
 - For instance, if you cook 4 cups of rice, add water up to the 4-cup level indicated on the scale.

Note

- The level marked inside the inner pot is just an indication. You can always adjust the water level for different types of grains and your own preference.
- Besides following the water level indications, you may also add rice and water at 1:1.2 ratio for rice cooking.
- Do not exceed the volume indicated or exceed the maximum water level, as this may cause the appliance to overflow.
- For the fast cooking with a large amount of rice, it's recommended to open the lid after 10-15 minutes to make sure the optimal taste and cooking result.

- Wipe off water outside of the inner pot and put it into the appliance.

Note

- Make sure that the outside of the inner pot is dry and clean, and that there is no foreign residue on the inside of the appliance.

- Close the lid (fig. 4), and put the plug in the power socket (fig. 5) and switch on the appliance.
- Press the White(Nasi Putih) or Brown(Nasi Merah) button (fig. 6), or select the Fast cook(Masak Cepat)/function by pressing the menu button (Menu) (fig. 7).
- Press the start button (Start) to start cooking (fig. 8).

- When the cooking is finished, you will hear 4 beeps and the selected cooking function light will be off.
- The Rice cooker will be in keep-warm mode automatically.
 - The keep-warm indicator lights up.

Note

- If the voltage is unstable at the area you live, it is possible that the Rice cooker overflows.
- After the cooking is finished, stir the rice and loosen it immediately to release excessive moisture for fluffy rice.
- Depending on the cooking conditions, the bottom portion of the rice may become slightly browned.
- Please stir rice after cooking, and you are recommended to consume it right after cooking for best nutrition and best taste. If you would like to keep rice for long hours and for many meals, it is best to keep rice in sealed plastic containers and keep them in the refrigerator and reheat it to avoid nutrient loss.
- If you want / need to change selection, you first need to press the "Keep warm/Cancel" (Menghangatkan/Cancel) button.

Cooking porridge/Slow cook

Cooking function	Estimated cooking time	Time regulation	Preset time
Porridge (Bubur)	2 hours	1-4 hours	1-24 hours
Slow cook	4 hours	3-10 hours	1-24 hours

- Put ingredients and water into the inner pot.
- Follow steps 4 to 5 in "Cooking rice".

Note

- Do not exceed the maximum water level indicated in the inner pot, as this may cause the Rice cooker to overflow.

- Select the porridge(Bubur) or slow cook function by pressing the menu button (Menu) (fig. 9) (fig. 10).
- Press the start button (Start) to start cooking (fig. 8).
- When the cooking is finished, you will hear 4 beeps and the selected cooking function light will be off. The Rice cooker will be in keep warm mode automatically.
 - The keep-warm indicator lights up.

Note

- You can use the porridge function to steam food.
- You can use the slow cook function to stew food.

Soup

Cooking function	Estimated cooking time	Time regulation	Preset time
Soup(Sup)	2 hours	1-4 hours	1-24 hours

- Put beans and water into the inner pot.
- Follow steps 4 to 5 in "Cooking rice".

Note

- Do not exceed the maximum water level indicated in the inner pot, as this may cause the Rice cooker to overflow.

- Select the Soup(Sup) function by pressing the menu button (Menu) (fig. 11).
- Press the start button (Start) to start cooking (fig. 8).
- When the cooking is finished, you will hear 4 beeps and the selected cooking function light will be off. The Rice cooker will be in keep warm mode automatically.
 - The keep-warm indicator lights up.

Steaming food

Cooking function	Estimated cooking time	Time regulation	Preset time
Steam (Kukus)	25 minutes	5-59 minutes	/

- Measure a few cups of water with the measuring cup.

Note

- To avoid boil-dry, add 2 scales of water at least into the inner pot.

- Pour the water into the inner pot (fig. 12).
- Put the steam basket into the inner pot.
- Put the food into the steam basket.
- Follow steps 4 to 5 in "Cooking rice".

Note

- Do not exceed the maximum water level indicated in the inner pot, as this may cause the Rice cooker to overflow.
- Add 5 cups of water at least to the inner pot when using the Steam function.

- Select the Steam(Kukus) function by pressing the menu button (Menu) (fig. 13).
- Press the start button (Start) to start cooking (fig. 8).
- When the cooking is finished, you will hear 4 beeps and the selected cooking function light will be off. The Rice cooker will be in keep warm mode automatically.
 - The keep-warm indicator lights up.

Cake

Cooking function	Estimated cooking time	Time regulation	Preset time
Cake(Kue)	45 minutes	/	/

- Whisk the ingredients for cake well.
- Coat the inner pot with some butter or cooking oil (fig. 14), and then pour the cake mixture into it (fig. 15).
- Follow steps 5 and 6 in "Cooking rice".
- Select the Cake function (Kue) by pressing the menu button (Menu) (fig. 16).
- Press the start button (Start) to start cooking (fig. 8).
- When the cooking is finished, you will hear 4 beeps and the selected cooking function light will be off. The Rice cooker will be in keep warm mode automatically.
 - The keep-warm indicator lights up.

- Open the lid and carefully take out the inner pot to cool down.
- After the inner pot is cool down, put a plate or cake rack on top of the pot, and then flip over to take the cake out.

Note

- Use a kitchen glove or a cloth, as the plate will be very hot.
- You can cook rice while steaming food. Do not exceed the volume indicated, as this may cause the Rice cooker to overflow.
- You can adjust the water level as needed.

How to cook cakes

- Preparation of raw material:
Small quantity: 3 eggs, 100g white sugar (about 2/3 cup), 100g cake powder (about 1 cup), 50g butter (about 1/3 cup), 18g milk (about 1/10 cup)
Large quantity: 5 eggs, 180g white sugar (about 1 cup), 180g cake powder (about 2 cups), 80g butter (about 2/3 cup), 36g milk (about 1/5 cup)

Note

- The user may adjust the raw material proportion as per personal tastes.
- Do not put in too much raw material, or the quality will be affected and even underdone.

- Mix round white sugar with egg, till the bubbles appear.

Note

- If the temperature of egg is too low, the user may use insulated water of 40°C to warm it. The cake made will be soft, loose and elastic.
- Whisk the egg, till the egg material flows down the egg whisk as silk.
- The vessel and egg whisk must be clean, if they have oil, the bubbles will be difficult to appear.
- Do not whisk the egg in the inner pot, to avoid scratching the nonstick coating.

- Add cake powder, and averagely mix them round by a wooden spoon.

Note

- Whisk the wooden spoon so as to fully mix the material round.

- Add milk and melted butter, quickly mix them round.

Note

- Melt the butter into liquid by insulated warm water.

Adjusting the cooking time

You can set the cooking time for some menus. Refer to the cooking time table in each chapter for the detailed regulating range.

- Choose the function you need.
- To set a different cooking time, press the cooking time button (Waktu Masak) (fig. 17), and the default cooking time starts flashing on the display.
- Press the hour button (Jam) to set the hour unit (fig. 18).
- After the hour unit is set, wait for a few seconds before the hour unit is confirmed, and the minute unit starts flashing on the display.
- Press the minute button (Menit) to set the minute unit (fig. 18).
- Press the start button to confirm the cooking time and start the cooking process.

Note

- You can adjust the cooking time only in the Porridge(Bubur), Soup(Sup) and Steam(Kukus) and function.

Preset time for delayed cooking

You can preset the delayed cooking time for some menus. The preset timer is available from 1 hour up to 24 hours.

Note

- The preset timer is not available in the Cake(Kue) function.
- The cooking process will be finished by the time the preset time has elapsed. If the preset time you set is shorter than the cooking time, the appliance will start the cooking process immediately.

- Choose the function you need.
- To preset time for delayed cooking, press the preset time button (Atur Waktu), and the default preset time starts flashing on the display (fig. 19).
- Press the hour button (Jam) to set the hour unit (fig. 18).
- After the hour unit is set, wait for a few seconds before the hour unit is confirmed, and the minute unit starts flashing on the display.
- Press the minute button (Menit) to set the minute unit (fig. 18).
- Press the start button to confirm the preset timer and start the cooking process.

6 Cleaning and Maintenance

Note

- Unplug the Rice cooker before starting to clean it.
- Wait until the Rice cooker has cooled down sufficiently before cleaning it.

Interior

- Inside of the top lid and the main body:
- Wipe with a damp cloth.
 - Make sure to remove all the food residues stuck to the Rice cooker.
- Heating element:
- Wipe with a damp cloth.
 - Remove food residues with a damp cloth.

