

Installation Guide

Stack Mount Kit for Philips G5 and MP5/20/30/40/50/60/70 Monitor

The purpose of this guide is to describe installation of the Stack Mount.

Parts Reference

The following parts and hardware are included with this installation kit (hardware not shown):

Item #	Description	Qty
1	Yoke, G5 Stack Mount with Swivel Mount Column	1
2	#10-32 x 9/16" Pan Head Machine Screw (PHMS)	4
3	#10 Flat Washer	4
4	Camlock Mounting Plate	1
5	M6 x 10mm Flat Head Machine Screw (FHMS)	3
6	M4 x 20mm PHMS	2
7	#6-32 x 3/8" PHMS	1
8	5/32" Hex Wrench	1
*9	Spacer, MP20/30	1
*10	M6 x 16mm Socket Head Cap Screw (SHCS)	2
*11	3/16" Hex Wrench	1

* See "MP20/30 non-Table Top Mount" on page 6 for use of these items.

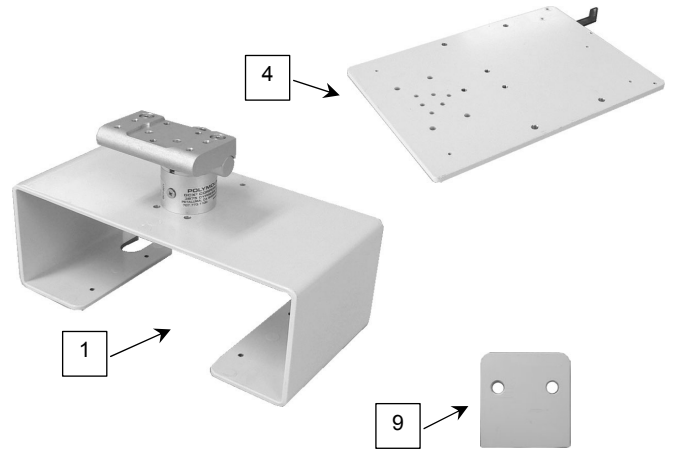

Tools required: Phillips screwdriver (not provided).

Mounting G5 in Stack Mount Yoke

Installation Note: Table Top Mounts supplied by Philips.

1. Fasten Table Top Mount to Camlock Mounting Plate with three (3) M6 x 10mm FHMS.

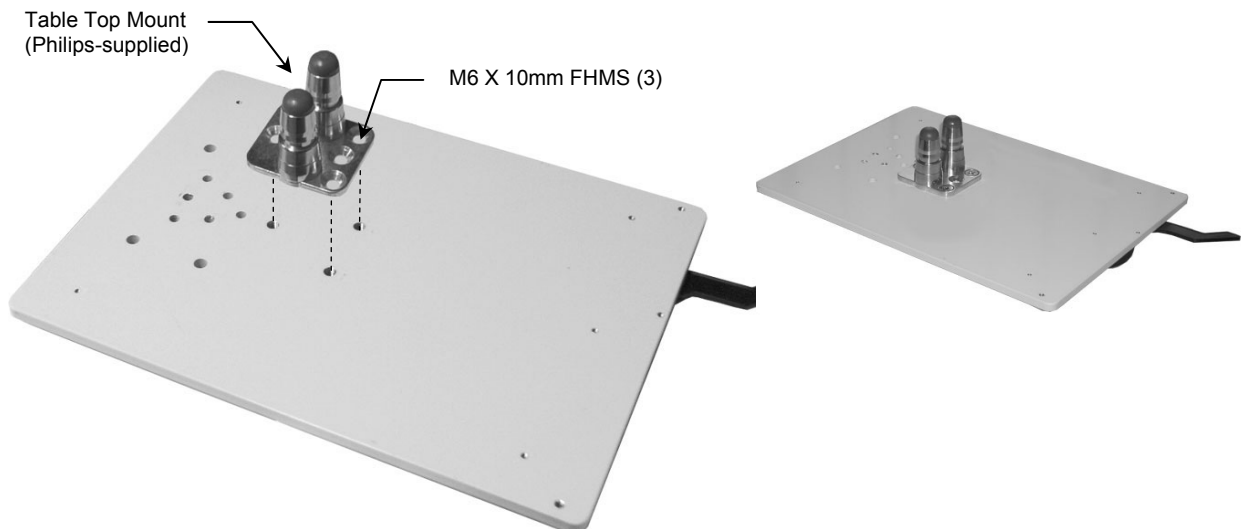

1. Mount G5 on table top mount in accordance with Philips instructions.



2. Slide the G5 Mounting Plate assembly into the Yoke as shown below left. The Yoke fits between the bottom of G5 and top of the Camlock Plate.

3. Align four (4) mounting holes in Camlock Plate with corresponding mounting holes Yoke. Fasten Camlock Plate to Yoke with four (4) #10-32 x 9/16" PHMS and #10 washers as shown below right.

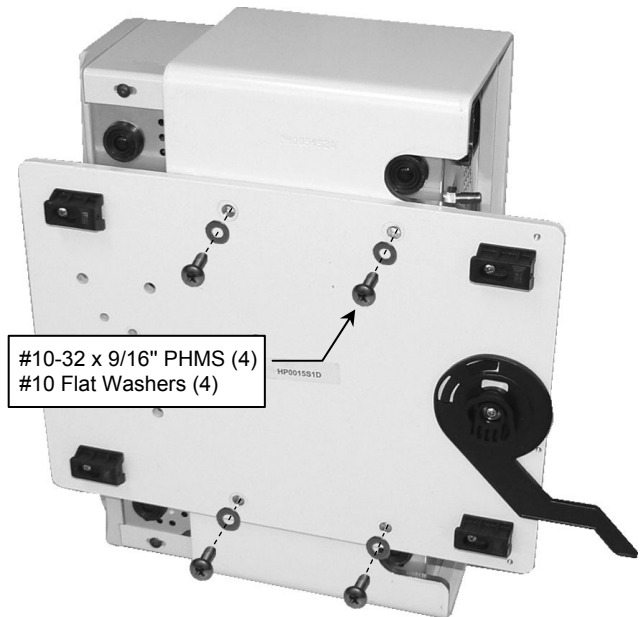
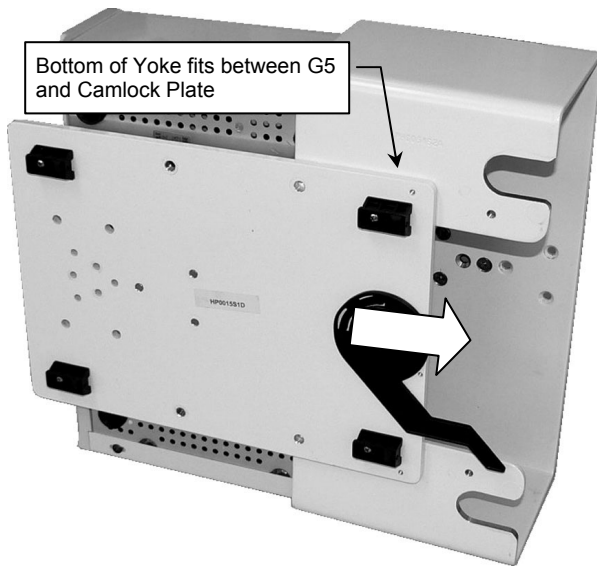

Attaching Philips Table Top Mount to Mounting Adapter

MP20/30 Installation Note: Do not attach the table top mount to the Mounting Adapter if you will be mounting an MP20/30 monitor equipped with the mounting interface shown in photo (right). See "Mounting the MP20/30 on non-Table Top Mount" (page 5) for instructions specific to this type of mounting plate.

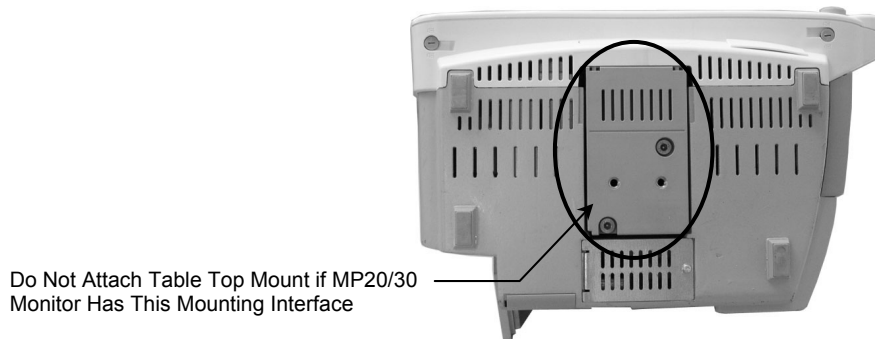

1. Fasten Table Top Mount to Mounting Adapter with one (1) M6 x 12mm FHMS and two (2) M6 x 8mm FHMS.

Table Top Mount
(Philips-supplied)



M6 X 12mm FHMS (1)

M6 X 8mm FHMS (2)

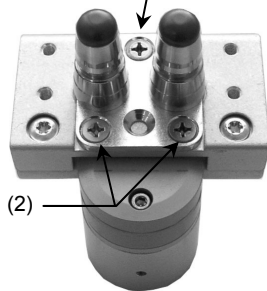

Mount G5 Stack Mount assembly in Camlock Rails

1. Insert the four (4) camlock feet in camlock rails. **Installation Note:** Camlock Lever must be in the "unlocked" position when mounting feet in Rails

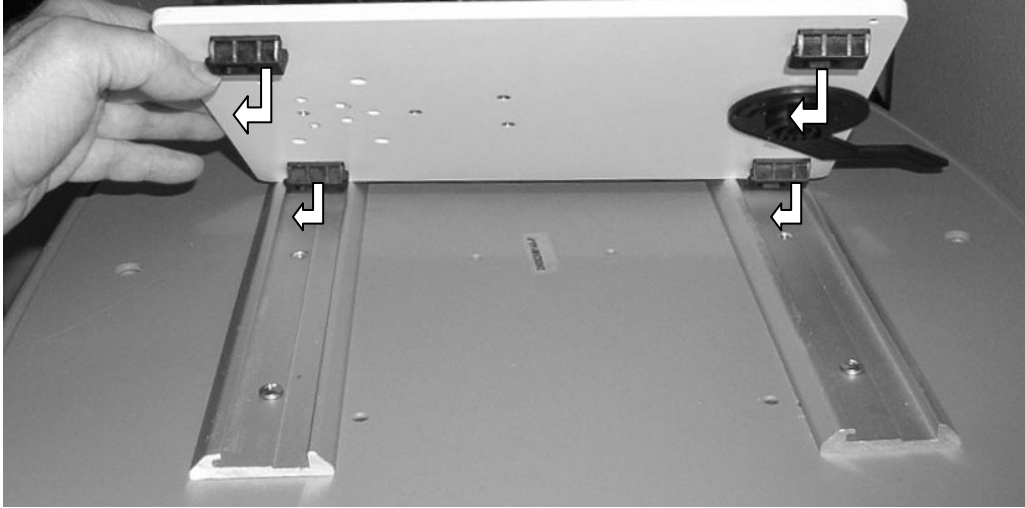

2. Lock the Camlock Plate by moving Camlock Lever from right to left.

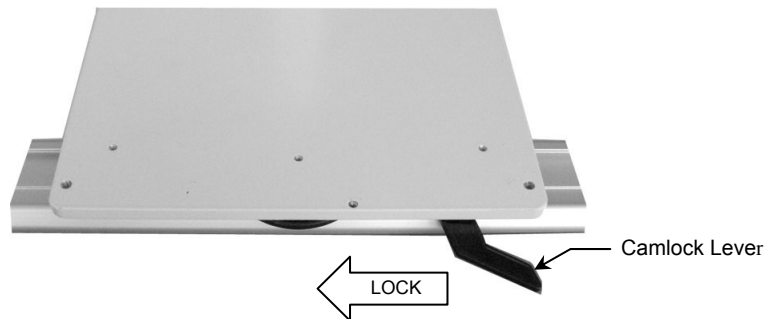

3. To prevent the Camlock Lever from being unlocked, insert one (1) #6-32 x 3/8" PHMS in the threaded hole to the right of the Lever (below right). To further secure the Camlock Mount in the Rails, insert one (1) M4 x 20mm PHMS in each of the two (2) threaded holes at the rear corners of the Mount (below right). Stop tightening these screws when they make contact with the bottom of the Rail.

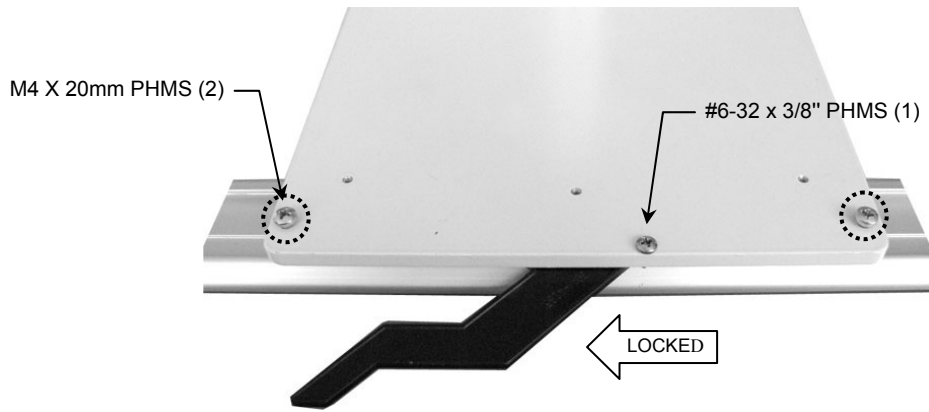

Mounting the Monitor

Mount the monitor in accordance with the Philips Table Top Mount instructions.



Mounting MP20/30 on non-Table Top Mount

Tools Required: 3/16" hex wrench.

1. Fit Spacer into recessed area on top of Mounting Adapter (below). Ensure Spacer remains between Mounting Adapter and monitor.

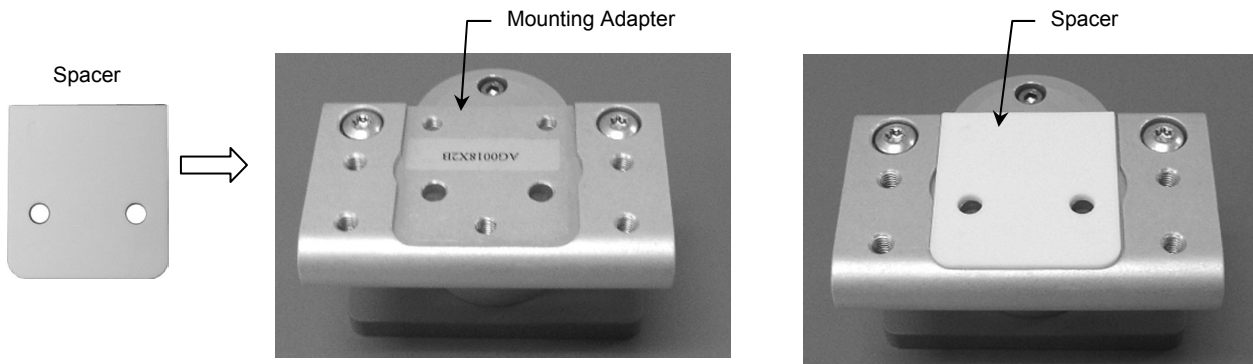

2. Using the 3/16" hex wrench, fasten the monitor to the Mounting Adapter with two (2) M6 x 16mm SHCS.

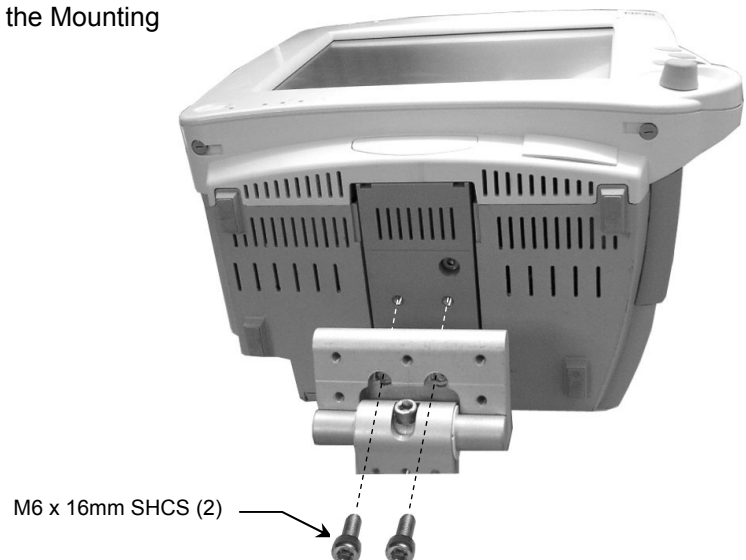

Adjusting Tilt and Swivel Tension

Tilt tension is adjusted by tightening or loosening the socket-head screw on the top of the Mount (right). A 5/32" hex wrench is provided for this adjustment. **Installation Note:** This adjustment should be made while the monitor is mounted.

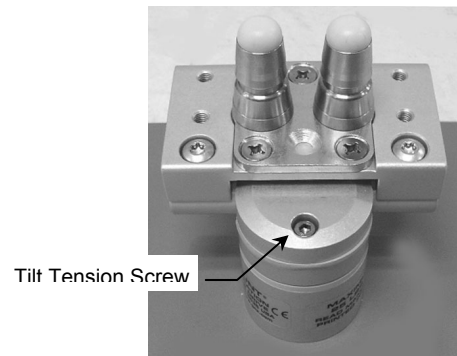

Swivel tension is adjusted by tightening or loosening the screw on the side of the column. **Installation Note:** This adjustment should be made while the monitor is mounted.

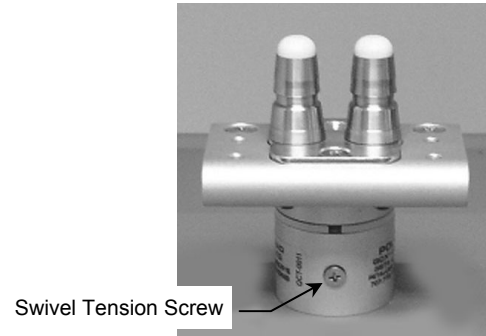

Periodic Maintenance

Periodically inspect all fasteners associated with the mounting system. Tighten or adjust fasteners as necessary for optimal operation and safety.

Cleaning the Mounting Assembly

1. The mounting assembly may be cleaned with most mild, non-abrasive solutions commonly used in the hospital environment (e.g. diluted bleach, ammonia, or alcohol solutions).
2. The surface finish will be permanently damaged by strong chemicals and solvents such as acetone or trichloroethylene.
3. Do not use Steel wool or other abrasive material.
4. Damage caused by the use of unapproved substances or processes will not be warranted. We recommend that any cleaning solution be tested on a small area of the mounting assembly that is not visible to verify compatibility.
5. Never submerge or allow liquids to enter the mounting assembly. Wipe any cleaning agents off of the mounting assembly immediately using a water-dampened cloth. Dry the mounting assembly thoroughly after cleaning.

CAUTION: GCX makes no claims regarding the efficacy of the listed chemicals or processes as a means for controlling infection. Consult your hospital's infection control officer or epidemiologist. To clean or sterilize mounted devices or accessory equipment, refer to the specific instructions delivered with those products